

"Turning the light on around the world"

Touch-Plate[®]
Lighting Controls
www.touchplate.com

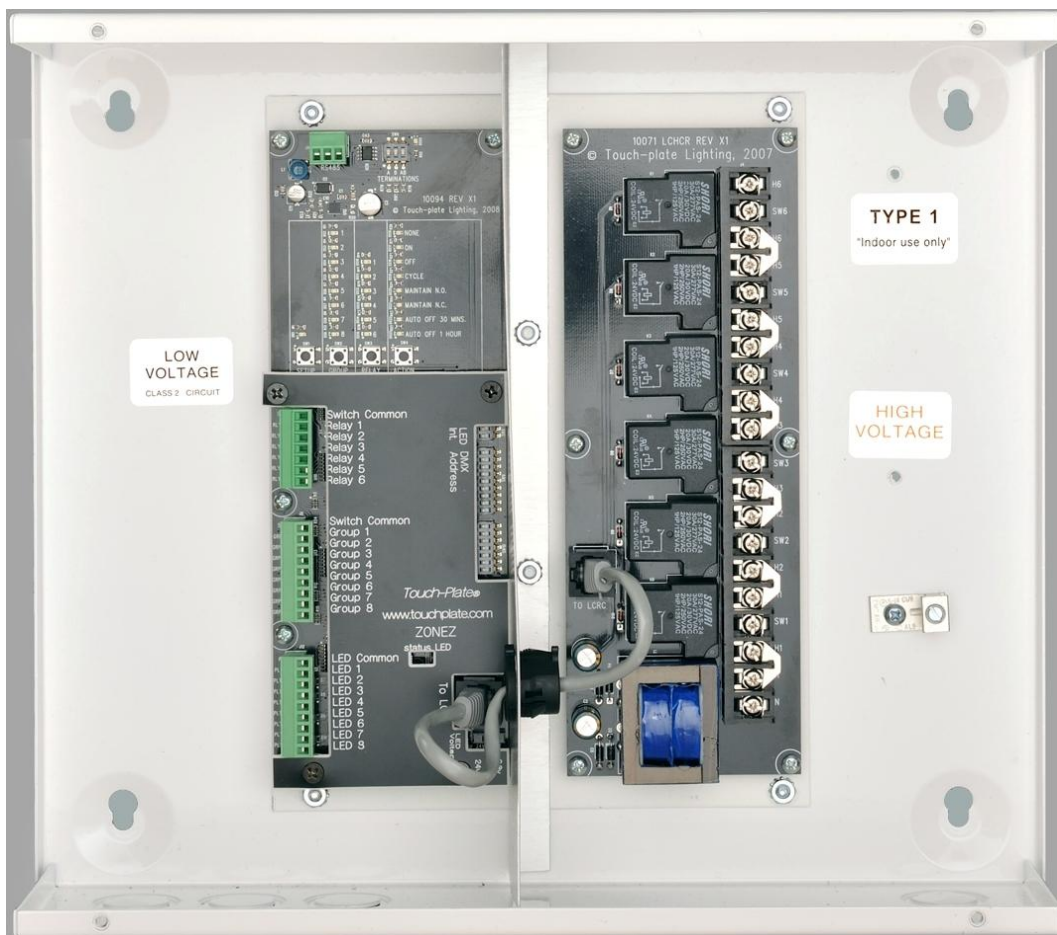

ZONEZ[®] - N



1830 Wayne Trace
Fort Wayne, IN 46803

Phone: 260.426.1565 / Fax: 260-426-1442

Visit us online at www.touchplate.com

Table of Contents

Locating Items in the Panel..... 3
Locating Items in the Panel..... 4
Introduction to the Low Voltage Relay Control Board (10094)..... 5
Introduction to the Relay Board (10071 / 10072). 6
Wiring the Low Voltage Relay Control Board (10094) – Switch Inputs. 7
Wiring the Low Voltage Relay Control Board (10094) – LED Inputs..... 8
Wiring the Low Voltage Relay Control Board (10094) – Group Functions 9
Programming the Low Voltage Relay Control Board (10094) – Group Functions. 10
Explanation of Action Meanings 11
Programming LED Inputs for Group Functions..... 11
Wiring the Relay Board (10071 / 10072) 12
Frequently Asked Questions 13
Warranty..... 14
Other Important Information..... 14

*****IF YOU HAVE A TIME-KEEPER® PLEASE USE THIS MANUAL & THE TIME-KEEPER® MANUAL FOR COMPLETE INSTALLATION INSTRUCTIONS*****

Locating Items in the Panel

Figure 3.1 shows an entire ZoneZ-N panel with 6 relays. The Relay Board is labeled 10071 or 10072. Each Relay Board has 6 Relays and a Power Supply mounted on it.

The Low Voltage Relay Control Board is labeled 10094. It can control up to 6 relays and provides Grouping, LED control, Option for a Time-Keeper® Networked System, and Action functions. In the panel the Low Voltage Relay Control Board(s) are almost always on the left side of the panel and the Relay Board(s) are almost always on the right side of the panel.

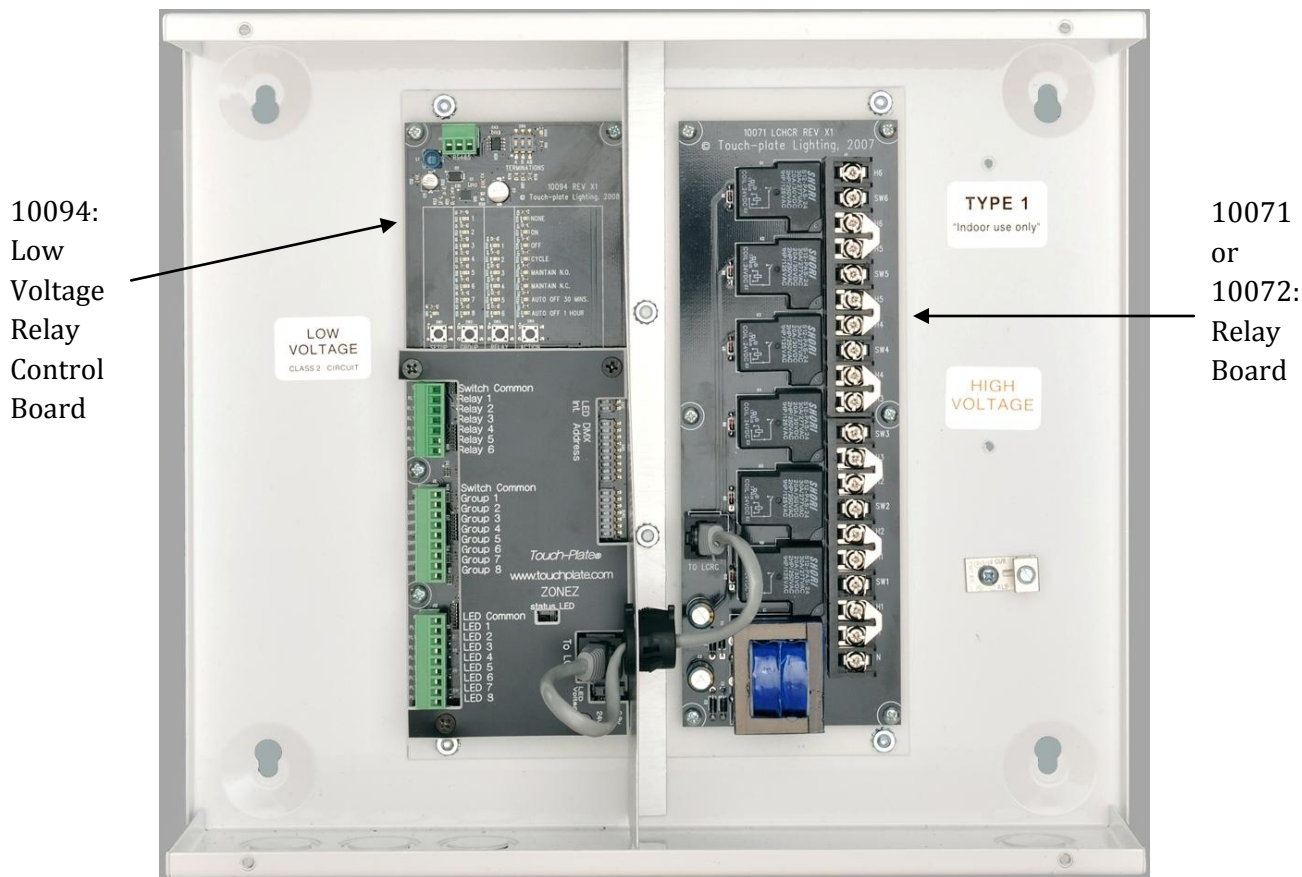

Figure 3.1

Retrofitting an Existing System

READ ALL INFORMATION TO COMPLETE A SUCCESSFUL INSTALLATION.

PRECAUTIONS: TO INSTALL A NEW RELAY PANEL, MAKE SURE TO TURN OFF POWER AT THE CIRCUIT BREAKER BEFORE REMOVING OR REPLACING ANY PARTS. BE SURE TO DISCONNECT AND REPLACE ANY EXISTING CONTROL STATION THAT HAVE PILOT LIGHTS / LAMPS BEFORE BRINGING POWER TO THE UPDATED RELAY PANEL.

Use the following instructions for disconnecting and removing parts in the existing system.

1. Label all wires- VERY IMPORTANT AND VITAL FOR A SUCCESSFUL INSTALLATION
 - a. Wires that need to be labeled are:
 - i. Low Voltage Switch Leg from the Control Station to the Relay (1550/2500/3000/4000) - Figure 4.2
 - ii. Common Wire from the Control Station to the Transverter (TVR-1/TPS-0120)-Figure 4.3
 - iii. Common Wire from the Control Station to the Pilot Light Transformer (PL-6/TPS-2001)*
 - iv. Wire(s) from the Breaker Panel to the Transverter (TVR-1 / TPS-0120)-Figure 4.4
 - v. Wire(s) from the Breaker Panel to the Lighting Load-Figure 4.4
2. Disconnect the Transverter (TVR-1 / TPS-0120)
3. Disconnect the Line Voltage from the relay (2 wires from the base of each relay)
 - a. Many times the 'Hot' wires are together
4. Disconnect the Low Voltage from the relay (Red and Brown wire from the coil)
5. Disconnect the Pilot Light Transverter from the Lighting Load and the Control Station(s)
 - a. The line voltage wires connected to the Pilot Light Transverter are no longer needed
6. Remove the enclosure with all Relays, Transverter, and Pilot Light Transformer(s) disconnected
 - a. If re-using the enclosure, only remove the Relays, Transverter, and Pilot Light Transformer(s)

****See Figures 4.1 – 4.5 for visual explanations****

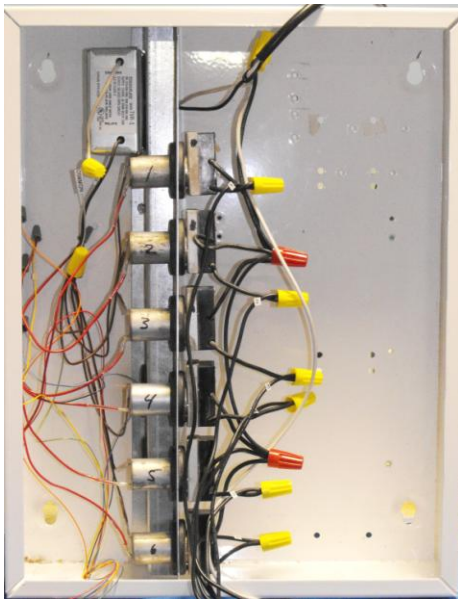

Figure 4.1
Shown: 6 Relay Panel made up of 2500B Relays and TVR-1 Transverter

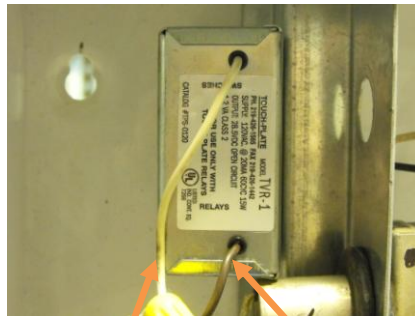

Figure 4.2
Label the Wires Indicated
Wire connected to White wire: Switches
Wire connected to Brown wire: Relays

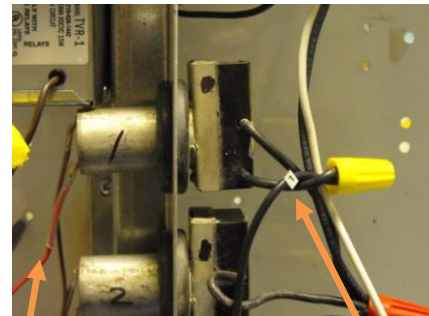

Figure 4.3
Label the Wires Indicated
Wire connected to Black Base Wire: Hot
Wire connected to Red Coil Wire: Switch Leg

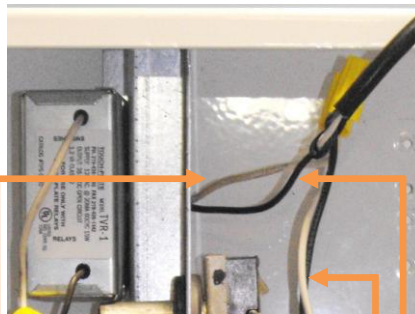

Figure 4.4
Label the Wires Indicated
White wire from Breaker: Neutral
Black wire from Breaker: Hot
White wire to Load: Neutral

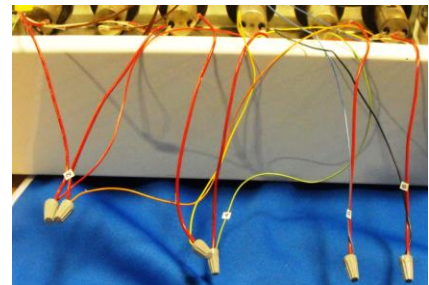

Figure 4.5
Label the Wires Indicated
Colored wires from the Switch:
Red, Orange, Yellow, Green, Blue, Black
Colors may vary in each application

Introduction to the Low Voltage Relay Control Board (10094)

Figure 5.1 shows a Low Voltage Relay Control Board labeled 10094. The low voltage Switch control portion is comprised of a 7 position Green connector. The Grouping control portion is comprised of a 9 position Green connector. The LED control portion is comprised of a 9 position Green connector also. If a Time-Keeper® is included, it is comprised of a 3 position Green connector at the top of the 10094 board.

The switch control Green connector is for the individual Switch Inputs for relays 1 through 6. This connector is the top one on the left side of the 10094 board. The board is labeled SC, RLY1, RLY2, RLY3, RLY4, RLY5, and RLY6 next to the switch control Green connector. See figure 5.1 for a visual description.

The Grouping control Green connector is for grouping inputs for Relays 1 through 6. This connector is underneath the switch control connector on the left side of the 10094 board. The board is labeled SC, GRP1, GRP2, GRP3, GRP4, GRP5, and GRP6 next to the grouping control Green connector. See figure 5.1 for a visual description.

The LED control Green connector is for LED inputs for Relays 1 through 6 or Groups 1 through 8. This connector is underneath the grouping control connector on the left side of the 10094 board. The board is labeled PC, PLT1, PLT2, PLT3, PLT4, PLT5, and PLT6 next to the LED control Green connector. See figure 5.1 for a visual description.

The RS485 Green connector is for Time-Keeper® networking. This connector is at the very top of the 10094 board.

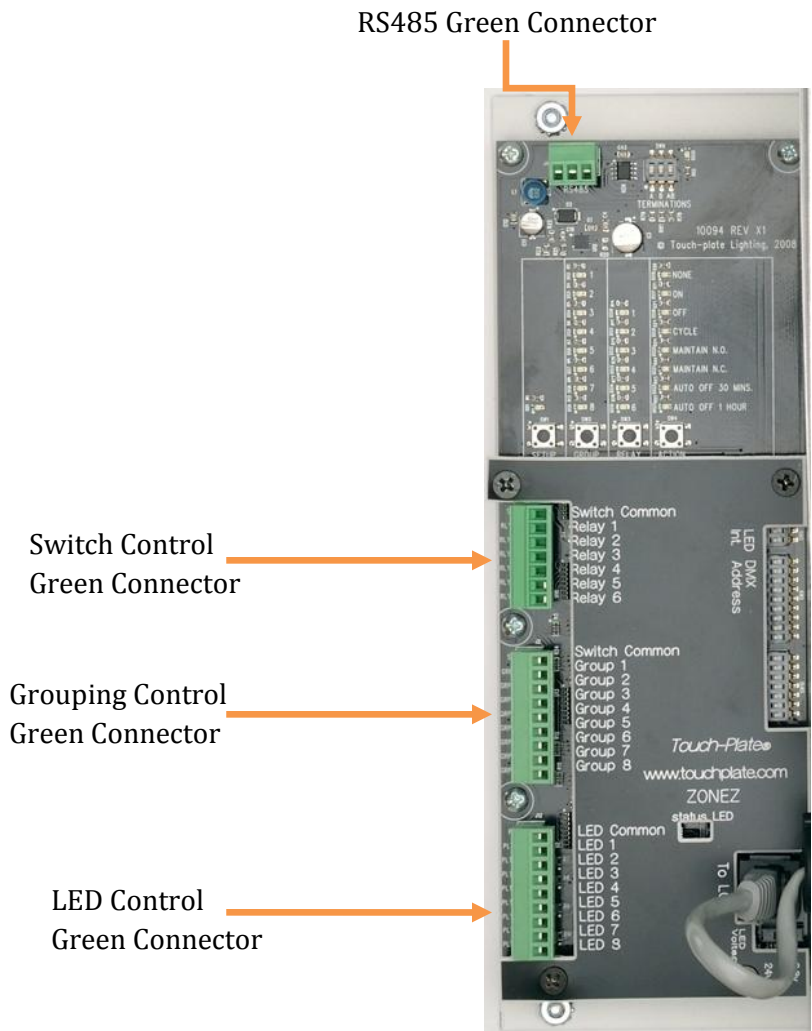

Figure 5.1

Introduction to the Relay Board (10071 / 10072)

Figure 6.1 shows a 10071 Relay Board. The 10071 Relay Board has electronically held relays that are rated at 20AMPS. There are 6 relays and a transformer per board. The transformer performs the same functions as the TVR-1 / TPS-0120, which supplies power to the relay and the low voltage circuitry. The 10071 Relay Board uses 20-AMP electrically held relays. The Relay Board will come from the factory with ‘jumpers’. ‘Jumpers’ allow all six (6) relays to share one (1) hot feed. If more than one (1) hot feed is desired or needed, the jumper(s) can be removed so the new hot feed can be wired.

Figure 6.2 shows a 10072 Relay Board. The 10072 Relay Board has mechanically latching relays that are rated at 50AMPS. There are 6 relays and a transformer per board. The transformer performs the same functions as the TVR-1 / TPS-0120, which supplies power to the relay and the low voltage circuitry. The 10072 Relay Board uses 20-AMP electrically held relays. The Relay Board will come from the factory with ‘jumpers’. ‘Jumpers’ allow all six (6) relays to share one (1) hot feed. If more than one (1) hot feed is desired or needed, the jumper(s) can be removed so the new hot feed can be wired.

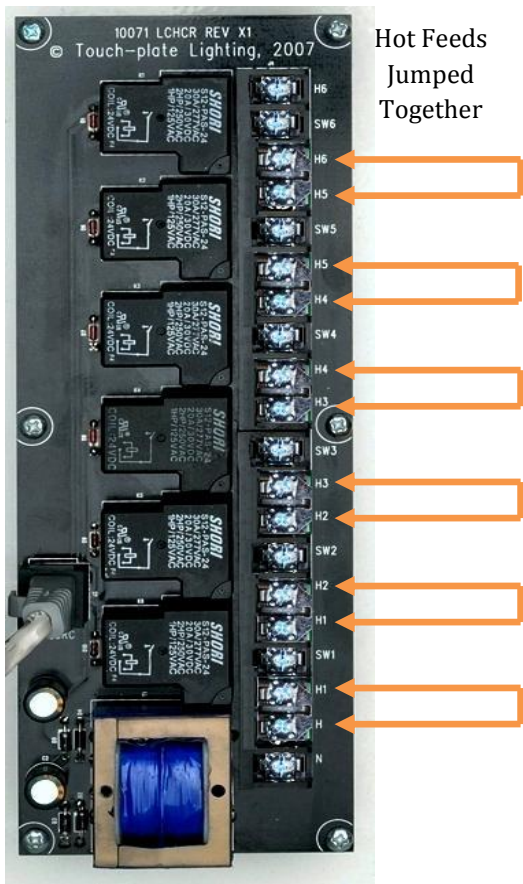

Figure 6.1

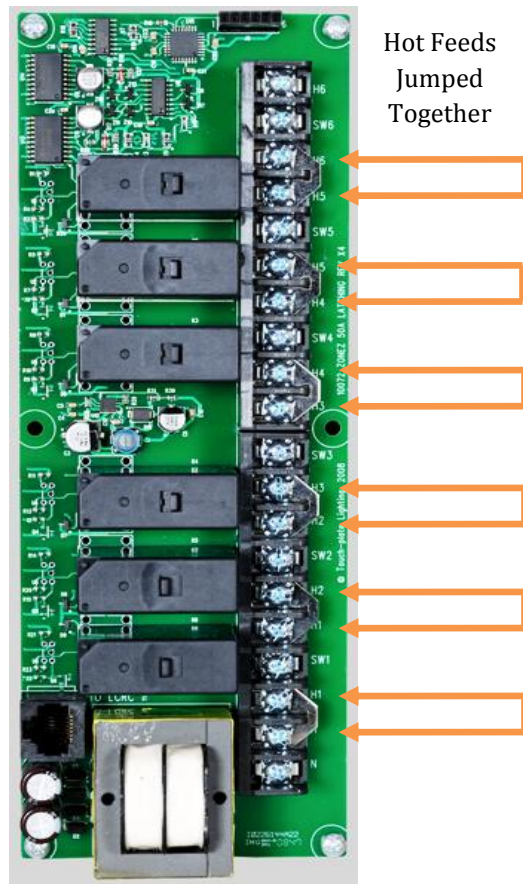

Figure 6.2

Wiring the Low Voltage Relay Control Board (10094) – Switch Inputs

Locate the wires labeled Switch Common (SC) and Switches 1-6. The Low Voltage Relay Control Board uses a descending order for switch inputs (Green connector).

Unplug the Green relay connector and use the screwdriver to open the screw on each of the terminals. See figure 7.1 for visual description.

Remove the connector and notate where the SC goes on the connector (board says SC – match this up to the connector). All switch commons can be put in the terminal associated with SC. A wire nut can be used to connect them altogether. Once there is one wire, it can be placed in the terminal corresponding to SC. See figure 7.2 for visual description.

Find the wire which was labeled switch 1 and screw it to the terminal labeled RLY1, which is underneath the SC terminal with the common wire(s). See figure 7.3 for visual description.

Follow the above pattern for all switches. When finished landing all the switch wires in the green connector, plug the connector back into the slot.

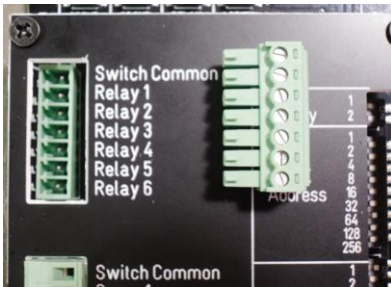

Figure 7.1



Figure 7.2

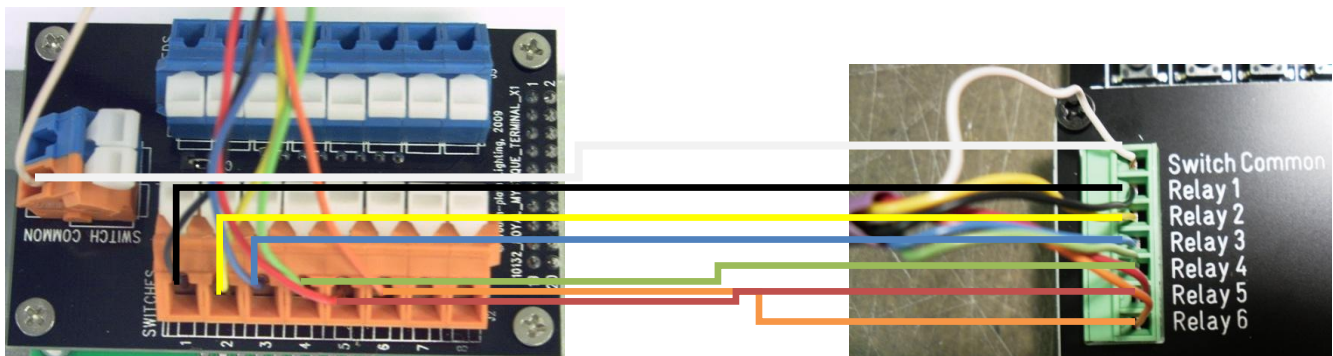

Figure 7.3

Wiring the Low Voltage Relay Control Board (10094) – LED Inputs

Locate the wires labeled LED Common or it could be labeled Pilot Common (PC) and LED wires 1-6. The Low Voltage Relay Control Board uses a descending order for LED inputs (Green connector).

Unplug the Green LED connector and use the screwdriver to open the screw on each of the terminals.

See figure 8.1 for visual description.

Remove the connector and notate where the PC goes on the connector (board says PC – match this up to the connector). All LED commons can be put in the terminal associated with PC. A wire nut can be used to connect them altogether. Once there is one wire, it can be placed in the terminal corresponding to PC.

See figure 8.2 for visual description.

Find the wire which was labeled LED 1 and screw it to the terminal labeled PLT1, which is underneath the PC terminal with the common wire(s). See figure 8.3 for visual description.

Follow the above pattern for all LEDs. When finished landing all the LED wires in the green connector, plug the connector back into the slot.

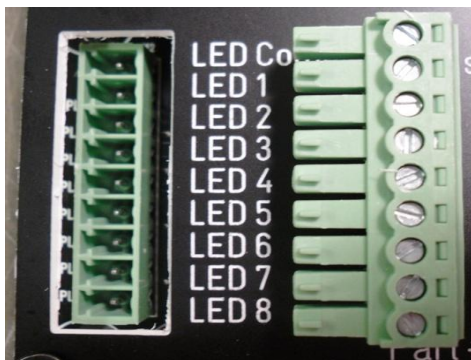

Figure 8.1

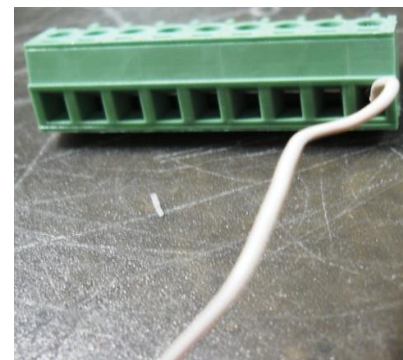

Figure 8.2

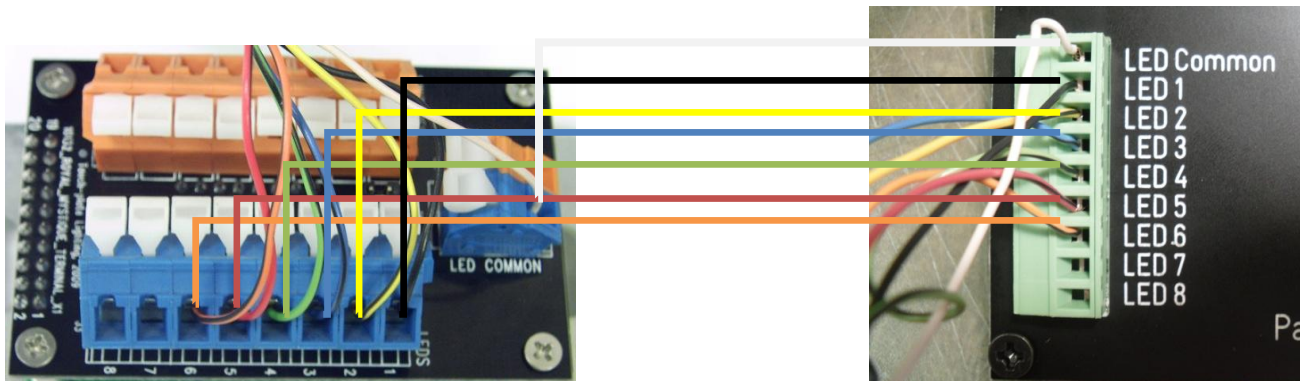

Figure 8.3

Wiring the Low Voltage Relay Control Board (10094) – Group Functions

If Grouping or Action functions are desired, then follow the instructions below. Each switch can control all six outputs. Although the switches are hooked up to the Grouping connector (green), they still control relays. Locate the wires labeled Switch Common (SC) and Switch wires 1-6. The Low Voltage Relay Control Board uses a descending order for Grouping inputs (Green connector).

Unplug the Grouping connector (green) and use the screwdriver to open the screw on each of the terminals. See figure 9.1 for visual description.

Remove the connector and notate where the SC goes on the connector (board says SC – match this up to the connector). All switch commons can be put in the terminal associated with SC. A wire nut can be used to connect them altogether. Once there is one wire, it can be placed in the terminal corresponding to SC. See figure 9.2 for visual description.

Find the wire which was labeled Switch 1 and screw it to the terminal labeled GRP1, which is underneath the SC terminal with the common wire(s). See figure 9.3 for visual description.

Follow the above pattern for all switches. When finished landing all the switch wires in the green connector, plug the connector back into the slot.

Once this step is finished, follow the instructions on the next page for programming the Low Voltage Relay Control Board.



Figure 9.1

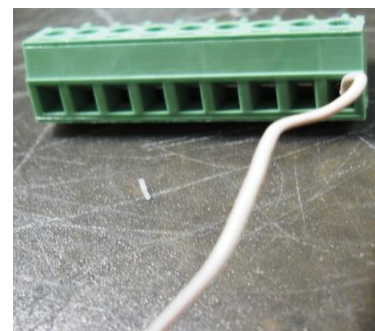

Figure 9.2

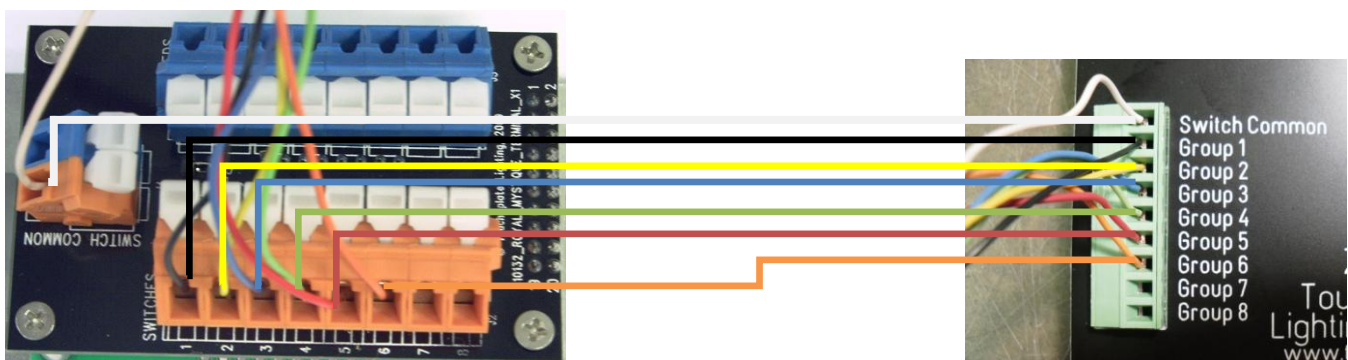

Figure 9.3

Programming the Low Voltage Relay Control Board (10094) - Group Functions

Make sure that the Relay Board has been wired and power has been brought to the system before this step can take place. Each switch needs to be determined what Action it will perform before programming take place. Once this has been decided, use the following steps to guide programming process.

1. Push the setup button once and the LED's at the top of the control board will light up.
2. Select which Group Input you want to program by pressing the Group button. Pressing the Group button over and over will scroll through each of the Group Inputs. Stop pressing the Group button on the Group number that is going to be programmed.
3. Press the Relay button to select the Relay that is going to be controlled. An Action can be set for each Relay. If it's desired that the Relay (load) is not to do anything, then press the Action button until the LED next to the word NONE is lit up. Press the Relay button again to program the next Relay and set the action for it. Continue for all 6 Relays.
4. Move to the next Group by pressing the Group button. Repeat this process for each Relay with that Group. 6 Groups can be programmed this way.
5. If using either the Maintain N.C. or Maintain N.O. Actions in a group, beware of the following. If multiple inputs are controlling the same thing, Maintain options can make the other programmed Actions not work.

See Figure 10.1 and 10.2 as two examples of programming the Grouping Inputs.



Figure 10.1



Figure 10.2

Explanation of Action Meanings

ACTION	MEANING
NONE	NO ACTION – RELAY WILL NOT DO ANYTHING
ON	THE RELAY WILL COME ON
OFF	THE RELAY WILL GO OFF
CYCLE	NORMAL FUNCTION FOR RELAY – TURNS OFF & ON
MAINTAIN N.O.	THE RELAY WILL BE NORMALLY OPEN – TYPICAL FOR A MOTION SENSOR
MAINTAIN N.C.	THE RELAY WILL BE NORMALLY CLOSED - TYPICAL FOR AN EMERGENCY SENSOR
AUTO OFF 30 MINS.	THE RELAY WILL TURN OFF AFTER 30 MINUTES
AUTO OFF 1 HOUR	THE RELAY WILL TURN OFF AFTER 1 HOUR

Programming LED Inputs for Group Functions

Since the Low Voltage Relay Control Board has the ability to control multiple things from one button (A Group), there may be an LED that corresponds to the Group. This can be done instead of just having the Relay correspond to the Group (which corresponds to the button location). Double press the Setup button and the Group LED will turn on. Select the LED number desired to turn on with each Group. Each Group is done separately and each LED is set separately. See Figure 11.1 for visual description.



Figure 11.1

Wiring the Relay Board (10071 / 10072)

The Relay Board (either 10071 or 10072) connects to the low voltage relay control board via RJ45 Cable. The transformer is wired from the circuit breaker panel with a Hot and Neutral feed.

Each relay on the Relay Board has a designation of “H1”, “H2”, “H3”, “H4”, “H5”, or “H6”. “H” stands for “HOT” and this wire must come from the circuit breaker panel. The relays do not need to have neutral feeds. There are duplicates of each Hot feed.

The “SW” designations are the Switched Leg of the relay. These are the terminals for the wire that goes to the light fixture being controlled. This is to provide ‘Jumpers’, which allow the same breaker to feed all 6 relays on one (1) Relay Board. If the lighting load is too much, a new circuit can be added to separate the relays, by removing the ‘jumper’.

The Relay Board is numbered opposite of the Low Voltage Control Board. The numbers ascend on the Relay Board with Relay # 1 (SW1) as the lowest relay on the board. See figure 12.1 for visual description.

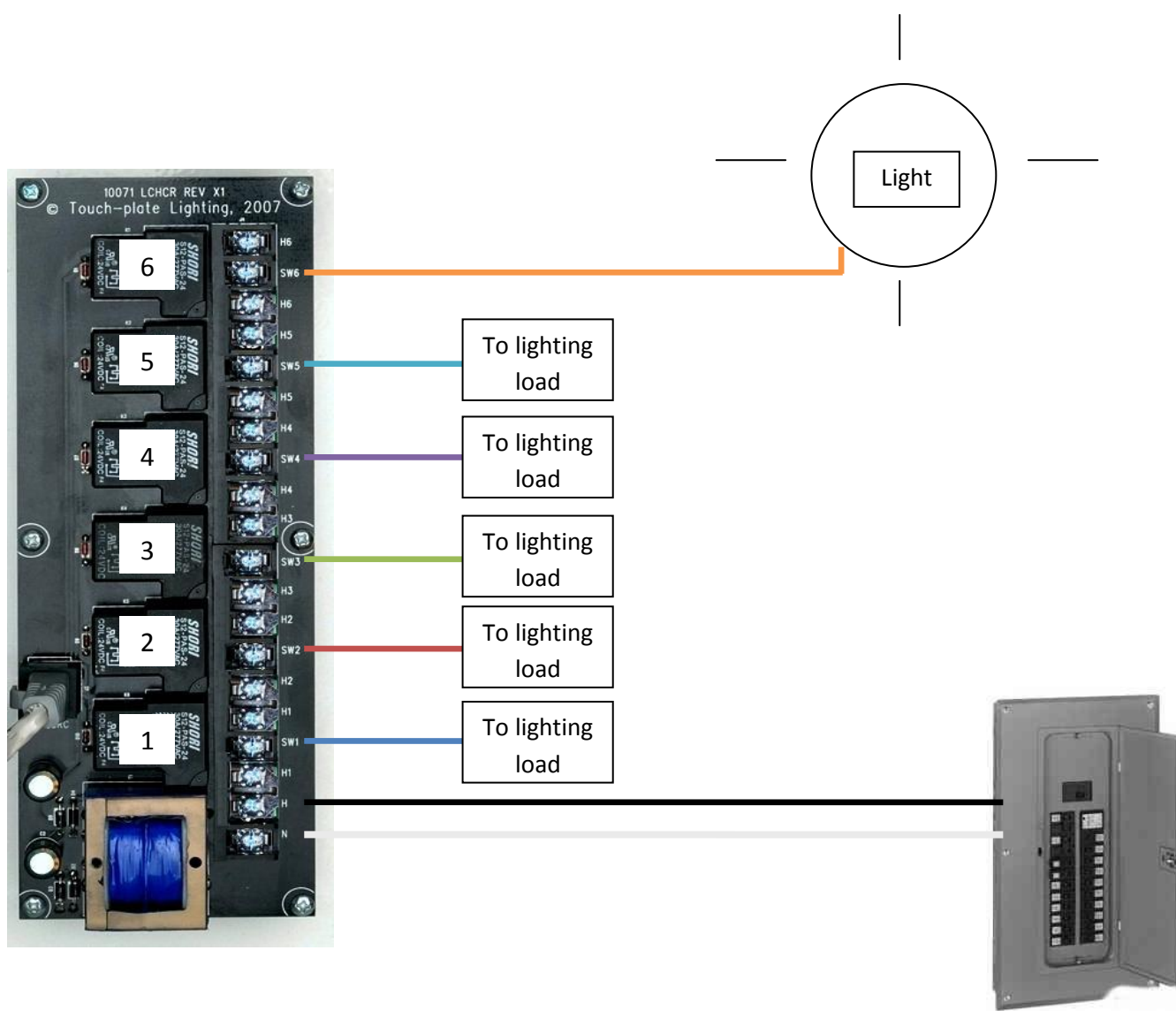

Figure 12.1

Frequently Asked Questions

1. Grouping – What is it?
 - a. Grouping allows for one button on a switch to control multiple relays.
 - i. Ex. In most bathrooms there are lights above the sink and above the shower. If it is desired that both lights should turn on at the same time with the push of one button, Grouping makes this possible.
2. What are all these “Other Functions”, “DMX Address”, and “Pilot Voltage”?
 - a. Other Functions are for those that have a DMX Network hooked up to a ZoneZ-N panel.
 - b. DMX Address is a number in a line of specific addresses. This has to be done because everything has a unique address and has to be programmed to do so. In most cases a Time-Keeper will accompany the panels so it can recognize the DMX programming.
 - c. Pilot Voltage is set to 24V so it can send the correct voltage to the switches. This should never be changed as it is factory set for the switches that correspond to the ZoneZ-N panel.
3. What does “Termination” at the top of the board mean?
 - a. It is the DMX Line Terminations. This will only be important if DMX Networking connected to the ZoneZ-N panel. A = Pull-Up, B = Pull-Down, AB = Line to Line.
4. Why are there so many “HOTS” and what are “jumpers”?
 - a. There are many “HOTS” so power can be fed to all six relays without using wire nuts. We want to help make the installation be as neat and orderly as possible. The way that the power is fed to all six relays is by using “jumpers”. “Jumpers” are metal inserts that jump the previous “HOT” to the next “HOT”.
5. How can switch commons be tracked during a retrofit?
 - a. The first way is if the transverter is still present and connected, the Switch Common wire will have a positive 28 to 31VDC reading. The second way to track the common wires is to unscrew a switch from the wall and look at what color wire is used for the common. If it is not obvious from these methods, the final option is to use a ringer (tone generator and receiver) and tone it out.

Warranty

Touch-Plate® warrants this hardware product against defects in materials or workmanship, under normal use for a period of ONE (1) year from date of shipment. If a hardware defect is to arise and a valid claim is received within the Warranty Period, Touch-Plate® will repair or replace the product at no charge.

This warranty does not apply to:

- a. Damage to unit(s) caused by accident, acts of God, inappropriate installation, faulty installation, or any negligent use;
- b. Unit(s) which have been subject to being taken apart or otherwise modified;
- c. Unit not used in accordance with instructions;
- d. The finish on any portion of the product, such as surface and/or weathering, as this is considered normal wear and tear;
- e. Non-Touch-Plate hardware installed by the user;
- f. Damage caused by Non-Touch-Plate products;
- g. Damage caused by operating the product outside the permitted or intended uses described by Touch-Plate®;
- or
- h. Specific plans or Specific application requirements, unless the plans and specifications have been forwarded to Touch-Plate and Touch-Plate has approved and accepted the plans in writing.

EXCEPT AS PROVIDED IN THIS WARRANTY, TOUCH-PLATE IS NOT RESPONSIBLE FOR DIRECT, SPECIAL, INCIDENTAL, OR CONSEQUENTIAL DAMAGES RESULTING FROM ANY BREACH OF WARRANTY OR CONDITION, INCLUDING BUT NOT LIMITED TO, INSTALLATION OR REPLACEMENT LABOR COSTS.

Other Important Information

1. If your product is capable of storing data, you should make periodic backup copies of the information contained to protect the contents as a precaution.
2. Do not install hardware in environments that have a temperature range of 0-60°C, as this could shorten the life span of the hardware.