

"Turning the light on around the world"

Touch-Plate[®]
Lighting Controls
www.touchplate.com

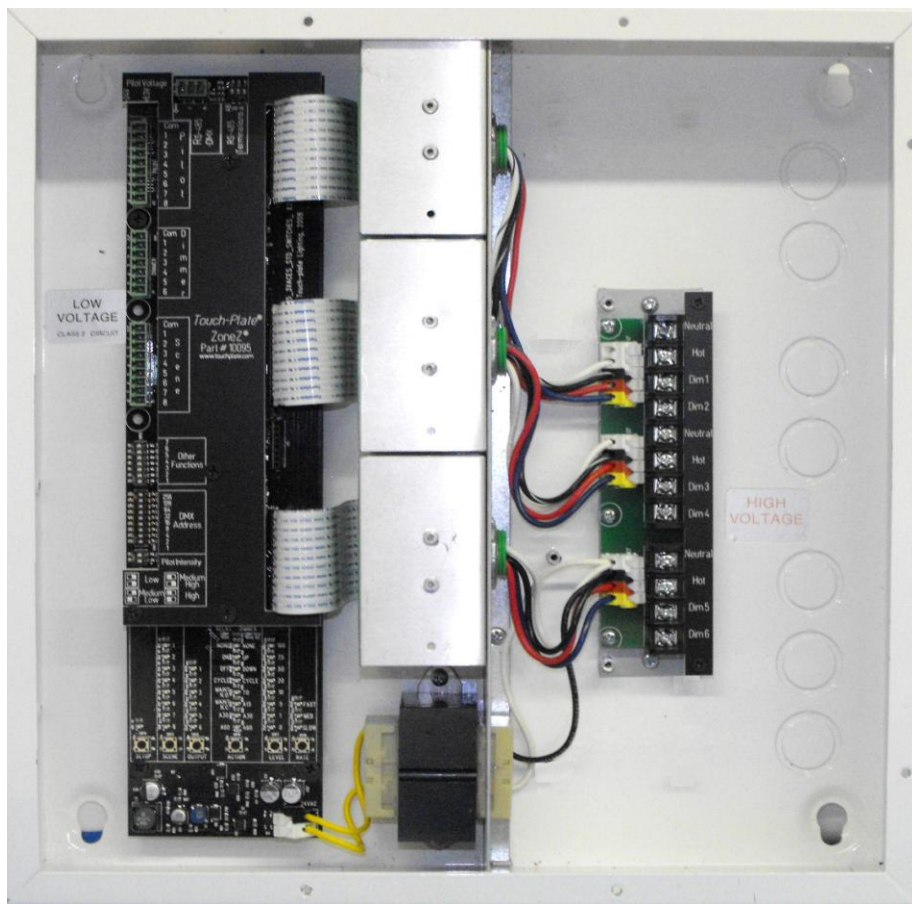

ZONES[®] - D



1830 Wayne Trace
Fort Wayne, IN 46803
Phone: 260.426.1565 / Fax: 260-426-1442
Visit us online at www.touchplate.com

Table of Contents

Locating Items in the Panel.....	3
Retrofitting an Existing System.....	4
Introduction to the Low Voltage Control Board (10095).....	5
Introduction to the High Voltage Connector Board (10137).....	6
Wiring the Low Voltage Control Board (10095) – LED Inputs.....	7
Wiring the Low Voltage Control Board (10095) – Dimmer Inputs.....	8
Wiring the Low Voltage Control Board (10095) – Scene Functions.....	9
Programming the Low Voltage Control Board (10095) – Scene Functions.....	10
Explanation of Action Meanings for Dimmer Modules.....	11
Explanation of Action Meanings for Relay Packs.....	11
Explanation of Level Meanings for Dimmer Modules.....	12
Programming LED Inputs for Scene Functions.....	12
Wiring the High Voltage Connector Board (10137).....	13
Frequently Asked Questions.....	14
Warranty.....	15
Other Important Information.....	15

*****IF YOU HAVE A TIME-KEEPER® PLEASE USE THIS MANUAL & THE TIME-KEEPER® MANUAL FOR COMPLETE INSTALLATION INSTRUCTIONS*****

Locating Items in the Panel

Figure 3.1 shows an entire ZoneZ-D panel with 3 Dimmer Modules. Each Dimmer Module Dims 2 loads. The Dimmer Modules are connected to the Low Voltage Control Board labeled 10095. A Dimmer Panel can also come with Relay Packs. This is only done if Dimming is not desired for all loads.

The Low Voltage Control Board (10095) can control up to 3 Dimmer Modules or 3 Relay Packs (10097-2R). It can also control a combination of Dimmer Modules and Relay Packs if desired. The Low Voltage Control Board (10095) provides Scene Control, LED control, Dimming Levels, and the future option of a Time-Keeper® Networked System.

The High Voltage Connector Board (10137) is where the line voltage connects to the panel. The panel is powered by a Transformer that links the High Voltage Connector Board to the Low Voltage Control Board. In the panel the Low Voltage Control Board, Dimmer Modules or Relay Packs are almost always on the left side of the panel. The High Voltage Connector Board is almost always on the right side of the panel. The Transformer is usually at the bottom of the panel.

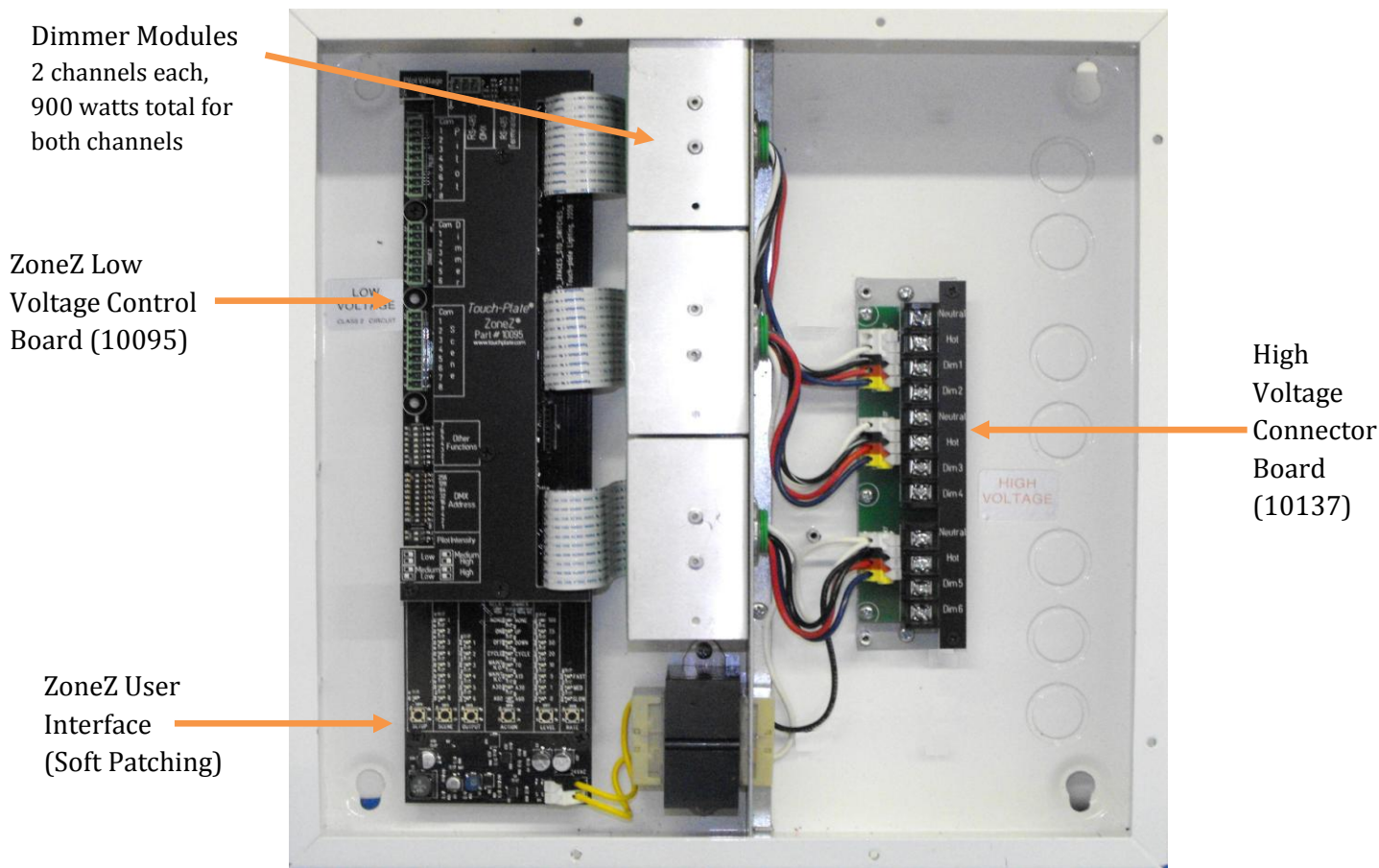

Figure 3.1

Retrofitting an Existing System

READ ALL INFORMATION TO COMPLETE A SUCCESSFUL INSTALLATION.

PRECAUTIONS: TO INSTALL A NEW RELAY PANEL, MAKE SURE TO TURN OFF POWER AT THE CIRCUIT BREAKER BEFORE REMOVING OR REPLACING ANY PARTS. BE SURE TO DISCONNECT AND REPLACE ANY EXISTING CONTROL STATION THAT HAVE PILOT LIGHTS / LAMPS BEFORE BRINGING POWER TO THE UPDATED RELAY PANEL.

Use the following instructions for disconnecting and removing parts in the existing system.

1. Label all wires– VERY IMPORTANT AND VITAL FOR A SUCCESSFUL INSTALLATION
 - a. Wires that need to be labeled are:
 - i. Low Voltage Switch Leg from the Control Station to the Relay (1550/2500/3000/4000) – Figure 4.2
 - ii. Common Wire from the Control Station to the Transverter (TVR-1/TPS-0120)-Figure 4.3
 - iii. Common Wire from the Control Station to the Pilot Light Transformer (PL-6/TPS-2001)*
 - iv. Wire(s) from the Breaker Panel to the Transverter (TVR-1 / TPS-0120)-Figure 4.4
 - v. Wire(s) from the Breaker Panel to the Lighting Load-Figure 4.4
2. Disconnect the Transverter (TVR-1 / TPS-0120)
3. Disconnect the Line Voltage from the relay (2 wires from the base of each relay)
 - a. Many times the ‘Hot’ wires are together
4. Disconnect the Low Voltage from the relay (Red and Brown wire from the coil)
5. Disconnect the Pilot Light Transverter from the Lighting Load and the Control Station(s)
 - a. The line voltage wires connected to the Pilot Light Transverter are no longer needed
6. Remove the enclosure with all Relays, Transverter, and Pilot Light Transformer(s) disconnected
 - a. If re-using the enclosure, only remove the Relays, Transverter, and Pilot Light Transformer(s)

See Figures 4.1 – 4.5 for visual explanations

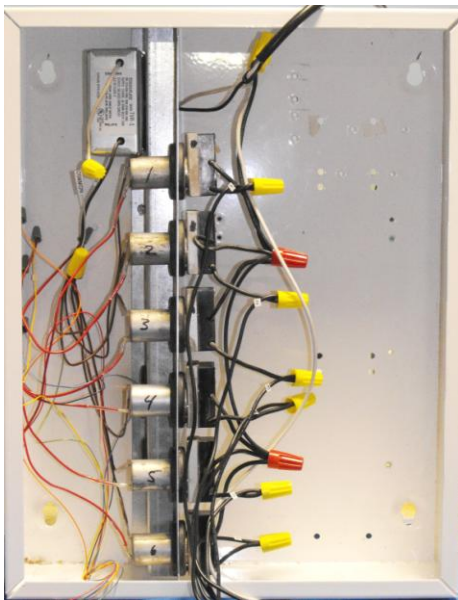

Figure 4.1
Shown: 6 Relay Panel made up of 2500B Relays and TVR-1 Transverter

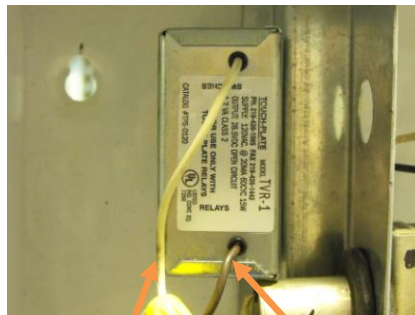

Figure 4.2
Label the Wires Indicated
Wire connected to White wire: Switches
Wire connected to Brown wire: Relays

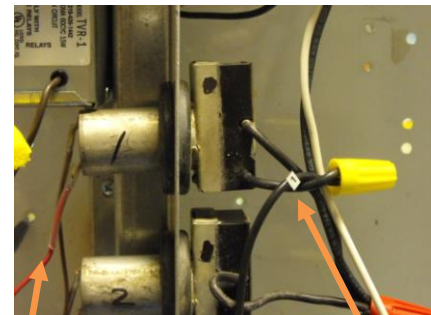

Figure 4.3
Label the Wires Indicated
Wire connected to Black Base Wire: Hot
Wire connected to Red Coil Wire: Switch Leg

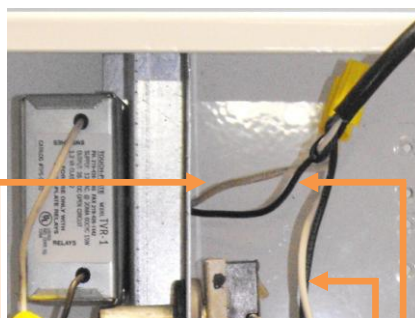

Figure 4.4
Label the Wires Indicated
White wire from Breaker: Neutral
Black wire from Breaker: Hot
White wire to Load: Neutral

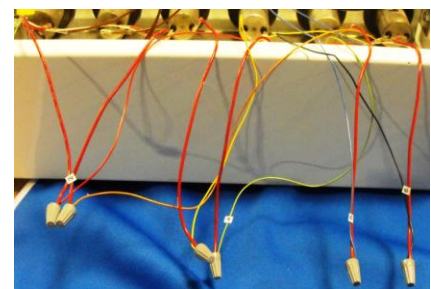

Figure 4.5
Label the Wires Indicated
Colored wires from the Switch:
Red, Orange, Yellow, Green, Blue, Black
Colors may vary in each application

Introduction to the Low Voltage Control Board (10095)

Figure 5.1 shows a ZoneZ Control Board (10095). The low voltage LED control portion is comprised of a 9 position Green connector. The Dimming control portion is comprised of a 7 position Green connector. The Scene control portion is comprised of a 9 position Green connector also. If a Time-Keeper® is included, it is comprised of a 3 position Green connector at the top of the 10095 board.

The LED control Green connector is for LED inputs for Dimmers 1 through 6 or Scenes 1 through 8. This connector is the top connector on the left side of the 10095 board. The board is labeled PC, 1, 2, 3, 4, 5, 6, 7, and 8 next to the LED control Green connector. See figure 5.1 for a visual description.

The Dimming control Green connector is for the individual Dimming inputs for all 3 Dimming Modules. This connector is underneath the LED connector on the left side of the 10095 board. The board is labeled SC, 1, 2, 3, 4, 5, and 6 next to the Dimming control Green connector. See figure 5.1 for a visual description.

The Scene control Green connector is for creating Scene inputs for Dimmers 1 through 6. This connector is underneath the Dimming control connector on the left side of the 10095 board. The board is labeled SC, 1, 2, 3, 4, 5, 6, 7, and 8 next to the Scene control Green connector. See figure 5.1 for a visual description.

The RS485 Green connector is for Time-Keeper® networking. This connector is at the very top of the 10095 board.

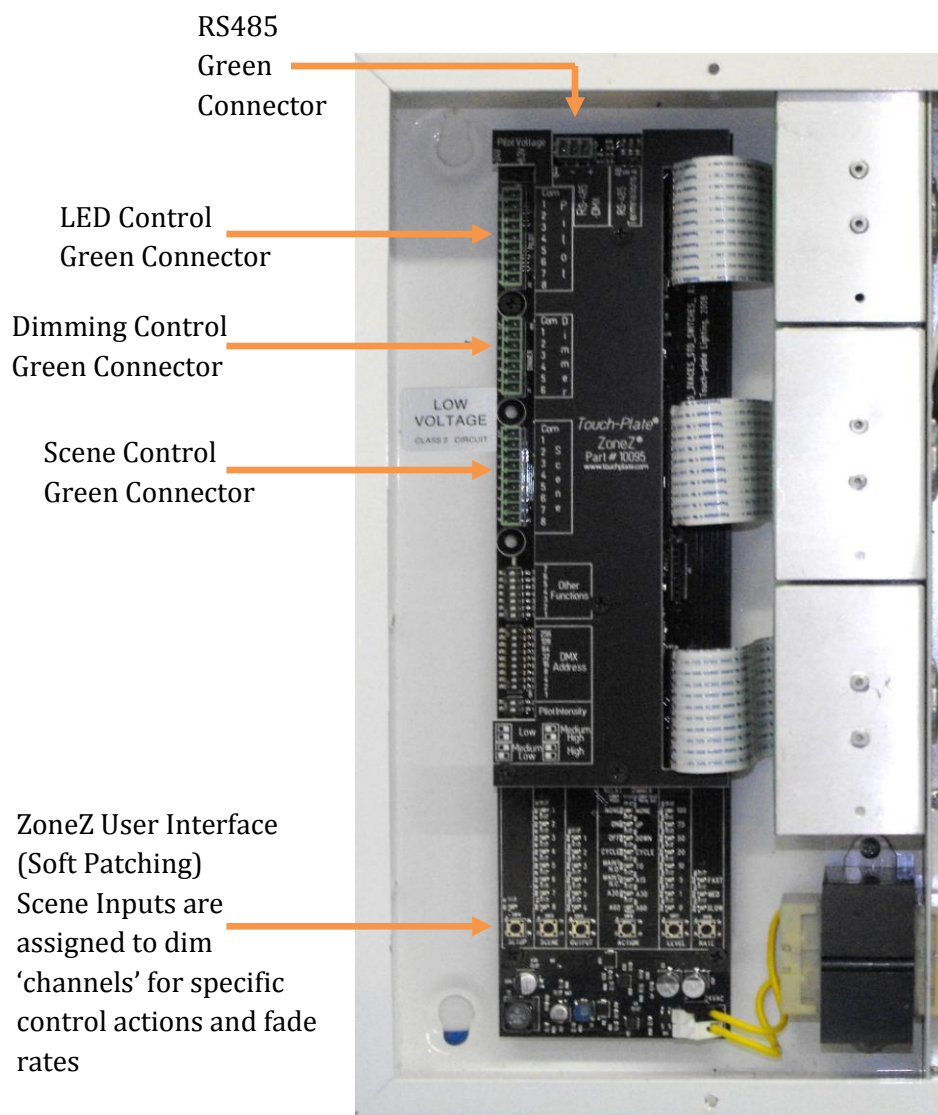

Figure 5.1

Introduction to the High Voltage Connector Board (10137)

Figure 6.1 shows the 10137 High Voltage Connector Board. The 10137 High Voltage Connector Board has 3 sets of color coded connectors on it and 12 screw terminals. The color coded connectors next to J1, at the top of the High Voltage Connector Board (10137), are where Dimmer Module 1 wires are landed. The color coded connectors next to J2, underneath the first set of color coded connectors, are where Dimmer Module 2’s wires are landed. The Dinkles next to J3, underneath the second set of color coded connectors, are where Dimmer Module 3’s wires are landed. The 12 terminals are where line voltage wires are brought in. The wires connected to the “Hot” will feed power to the Dimmer Modules, the “Dim#” wires to the lighting load. Each load dimmed will need a Neutral (they are tied together on the 10137)and they can be connected to any of the 3 available screw terminals. See figure 6.1 for a visual description.

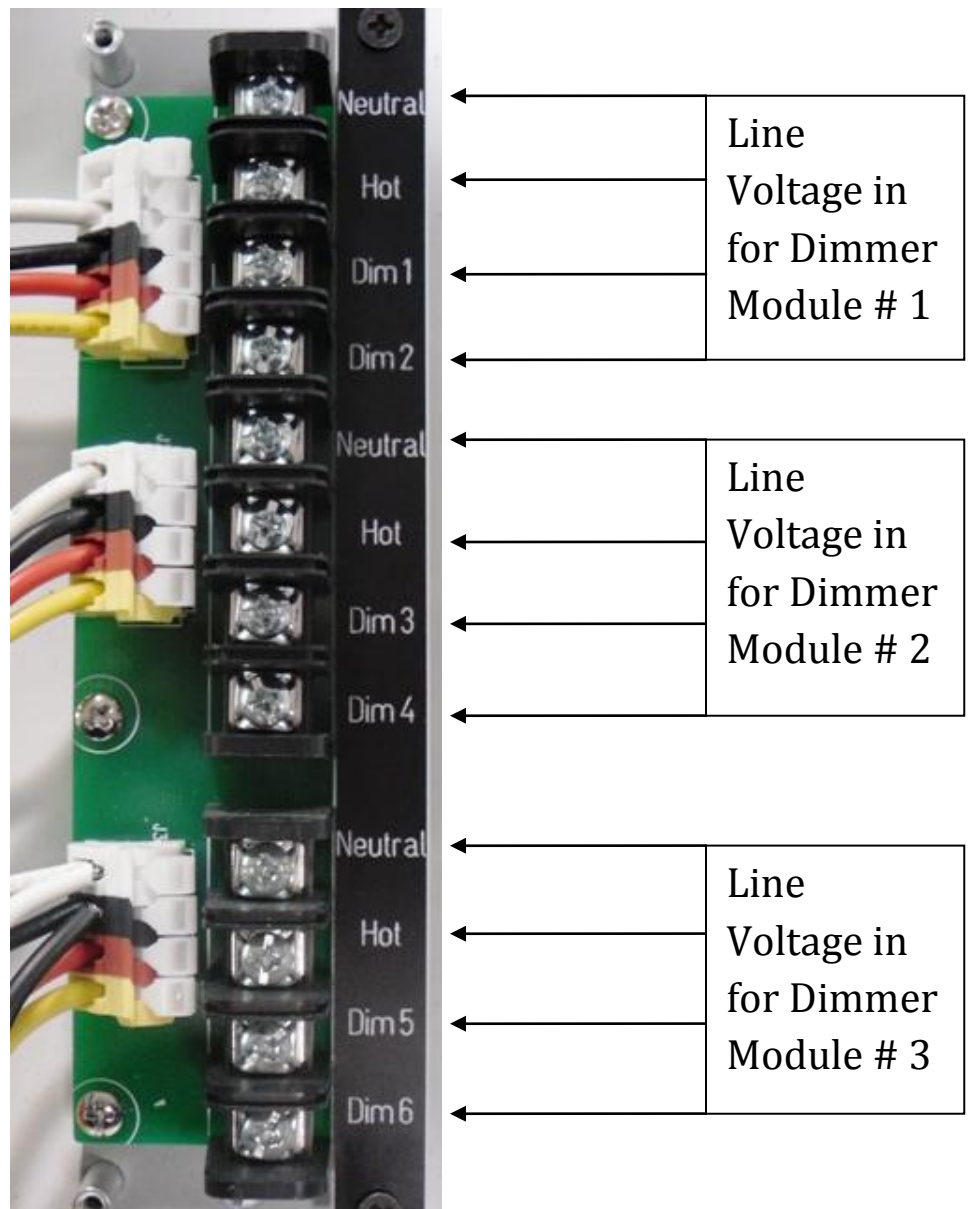

Figure 6.1

Wiring the Low Voltage Control Board (10095) - LED Inputs

Locate the wires labeled LED Common or it could be labeled Pilot Common (PC) and LED wires 1-6. The Low Voltage Control Board uses a descending order for LED inputs (Green connector).

Unplug the Green LED connector and use the screwdriver to open the screw on each of the terminals.

See figure 7.1 for visual description.

Remove the connector and notate where the PC goes on the connector (board says PC - match this up to the connector). All LED commons can be put in the terminal associated with PC. A wire nut can be used to connect them altogether. Once there is one wire, it can be placed in the terminal corresponding to PC.

See figure 7.2 for visual description.

Find the wire which was labeled LED 1 and screw it to the terminal labeled 1, which is underneath the PC terminal with the common wire(s). See figure 7.3 for visual description.

Follow the above pattern for all LEDs. When finished landing all the LED wires in the green connector, plug the connector back into the slot.

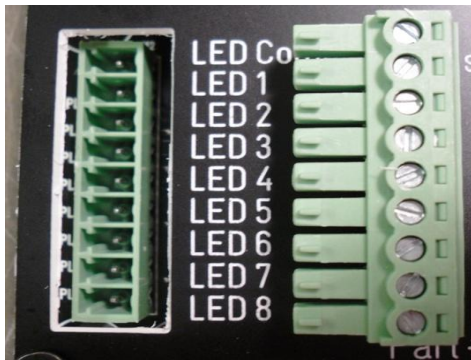

Figure 7.1

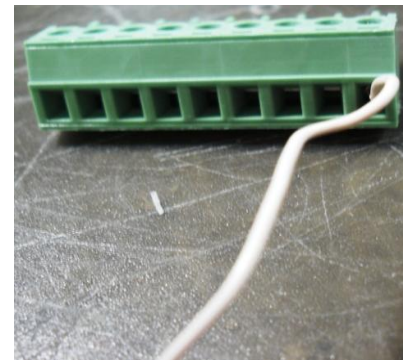

Figure 7.2

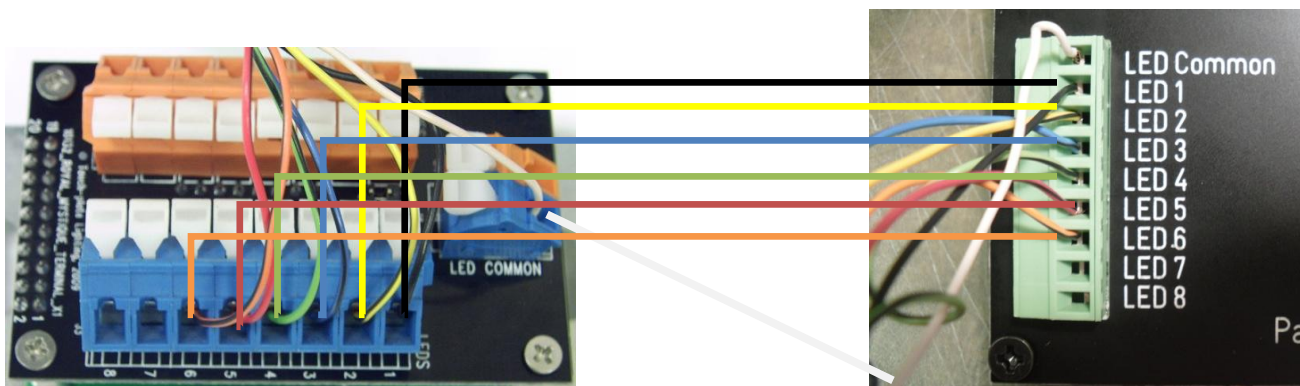

Figure 7.3

Wiring the Low Voltage Relay Control Board (10095) – Dimmer Inputs

Dimmer Inputs should be used when Dim Cycle is desired. Dim Cycle has four options, ‘Tap to Preset’, ‘Tap to OFF’, ‘Press and Hold to Dim UP’, and ‘Press and Hold to Dim Down’. ‘Cycle’ is a term to indicate it changes to next state. If OFF, the next tap will take to Preset, or if held ramp Up. If already ON, next tap will fade to OFF, or if held will ramp Up. When ‘Ramping’ is done, the level attained is memorized as the preset. If exact Dimming levels are desired, then use the available ‘Scene’ inputs. (Go to the next page for wiring Scene instructions.)

Locate the wires labeled Switch Common (SC) and Switches 1-6. The Low Voltage Control Board uses a descending order for switch inputs (Green connector).

Unplug the Green relay connector and use the screwdriver to open the screw on each of the terminals. See figure 8.1 for visual description.

Remove the connector and notate where the SC goes on the connector (board says SC – match this up to the connector). All switch commons can be put in the terminal associated with SC. A wire nut can be used to connect them altogether. Once there is one wire, it can be placed in the terminal corresponding to SC. See figure 8.2 for visual description.

Find the wire which was labeled switch 1 and screw it to the terminal labeled 1, which is underneath the SC terminal with the common wire(s). See figure 8.3 for visual description.

Follow the above pattern for all Dimming wires. When finished landing all the wires in the green connector, plug the connector back into the Dimmer slot.

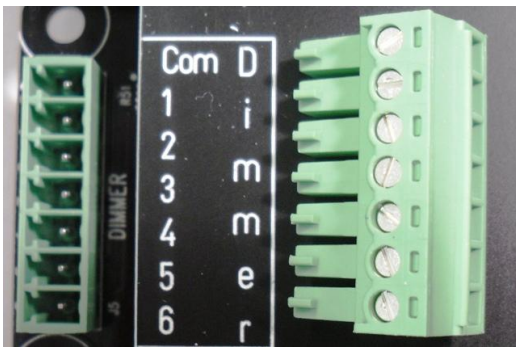

Figure 8.1

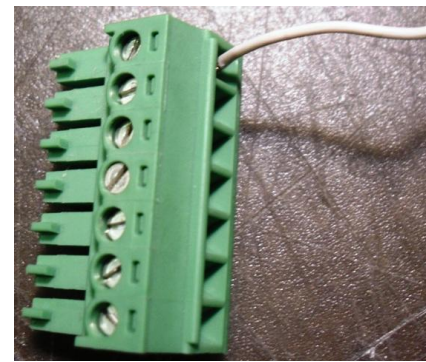

Figure 8.2

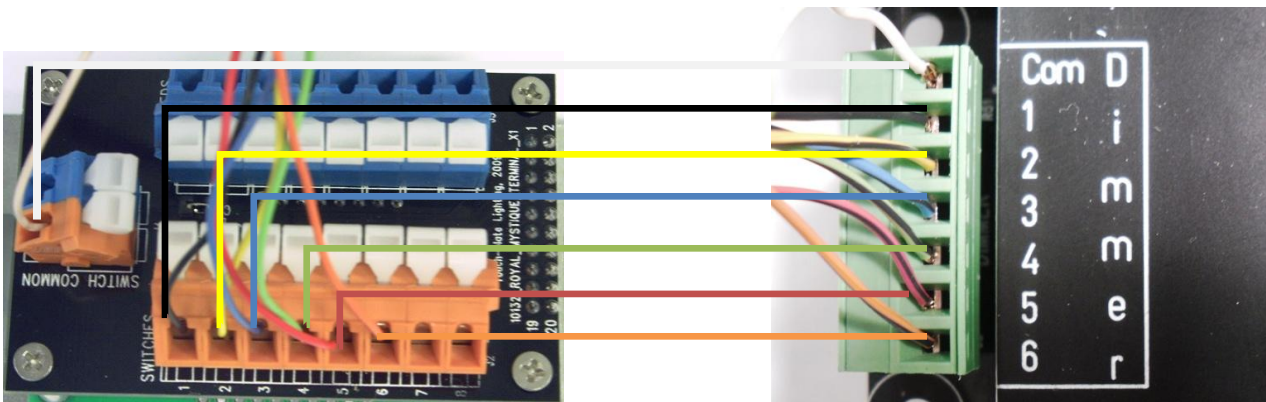

Figure 8.3

Wiring the Low Voltage Relay Control Board (10095) – Scene Functions

If programmed Scenes are desired, then use the following instructions. Scenes are used when exact Dimming levels are desired. Although the switch wires are hooked up to the Scene connector (green), they still control Dimming functions.

Locate the wires labeled Switch Common (SC) and Switch wires 1-6. The Low Voltage Control Board uses a descending order for Scene Inputs (Green connector).

Unplug the Scene connector (green) and use the screwdriver to open the screw on each of the terminals. See figure 9.1 for visual description.

Remove the connector and notate where the SC goes on the connector (board says SC – match this up to the connector). All switch commons can be put in the terminal associated with SC. A wire nut can be used to connect them altogether. Once there is one wire, it can be placed in the terminal corresponding to SC.

See figure 9.2 for visual description.

Find the wire which was labeled Switch 1 and screw it to the terminal labeled 1, which is underneath the SC terminal with the common wire(s). See figure 9.3 for visual description.

Follow the above pattern for all Dimming wires. When finished landing all the wires in the green connector, plug the connector back into the slot.

Once this step is finished, follow the instructions on the next page for programming the Low Voltage Control Board.

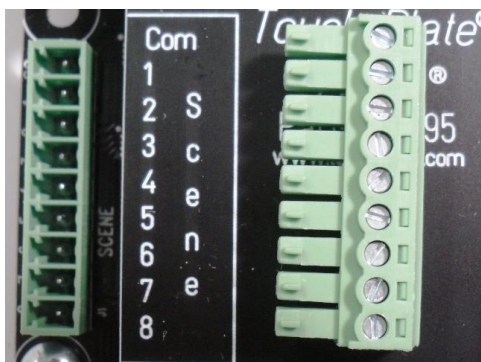

Figure 9.1

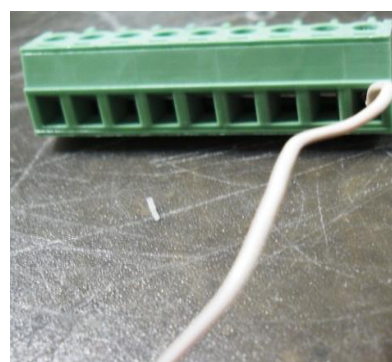

Figure 9.2

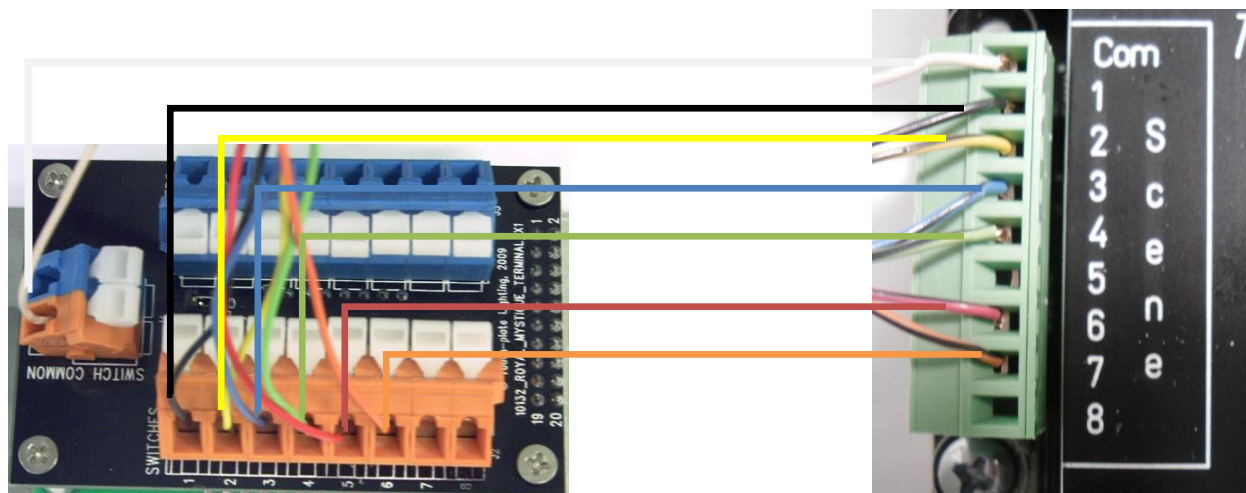

Figure 9.3

Programming the Low Voltage Relay Control Board (10095) - Scene Functions

Make sure that the High Voltage Connector Board has been wired and power has been brought to the system before this step can take place. Each switch needs to be determined what Action it will perform before programming take place. Once this has been decided, use the following steps to guide programming process.

1. Push the setup button once and the LED's at the bottom of the control board will light up.
2. Select which Scene Input you want to program by pressing the Scene button. Pressing the Scene button over and over will scroll through each of the Scene Inputs. Stop pressing the Scene button on the Scene number that is going to be programmed.
3. Press the Output button to select the Dimmer that is going to be controlled. An Action can be set for each Dimmer. If it's desired that the Dimmer (load) is not to do anything different, then press the Action button until the LED next to the word NONE is lit up. Press the Output button again to program the next Dimmer and set the scene action for it. Continue for all 6 Dimmers.
4. Move to the next Scene by pressing the Scene button. Repeat this process for each Dimmer with that Group. 8 Scenes can be programmed this way.
5. Maintain N.C. or Maintain N.O. devices are available to activate a Scene. Do not wire additional momentary switch buttons into the same Scene Input, Maintain options can make the other programmed Actions not work.
6. If an exact level is desired for the lights to Dim up or down to, press the Action button until the LED next to the word "TO" is lit up. Press the Level button over and over until the LED is lit up next to the appropriate Level desired.
7. If the rate at which the light Dims up or down to is desired, press the Rate button over and over until the LED is lit up next to the desired Dimming speed.

See Figures 10.1 through 10.6 as an example of programming the one Scene Input.



Figure 10.1



Figure 10.2



Figure 10.3



Figure 10.4



Figure 10.5



Figure 10.6

Explanation of Action Meanings for Dimmer Modules

ACTION	MEANING
NONE	NO ACTION – DIMMER WILL NOT DO ANYTHING
UP	THE DIMMER WILL RAMP UP FROM START LEVEL WHEN HELD
DOWN	THE DIMMER WILL RAMP DOWN FROM START LEVEL WHEN HELD
CYCLE	NORMAL FUNCTION FOR DIMMER – DIMS UP & DOWN WHEN HELD, or TAP to PRESET, TAP to OFF
TO	THE DIMMER IS ASSIGNED A SPECIFIC DIMMING LEVEL (using next column on User Interface)
A15	THE DIMMER WILL GO ON, THEN TURN OFF AFTER 15 MINUTES
A30	THE DIMMER WILL GO ON, THEN TURN OFF AFTER 30 MINUTES
A60	THE DIMMER WILL GO ON, THEN TURN OFF AFTER 1 HOUR

Explanation of Action Meanings for Relay Packs

ACTION	MEANING
NONE	NO ACTION – RELAY WILL NOT DO ANYTHING
ON	THE RELAY WILL COME ON
OFF	THE RELAY WILL GO OFF
CYCLE	NORMAL FUNCTION FOR RELAY – CHANGES TO NEXT STATE
MAINTAIN N.O.	TYPICAL FOR A MOTION SENSOR, RELAY WILL GO TO ON WHEN CONTACTS GO CLOSED
MAINTAIN N.C.	TYPICAL FOR AN EMERGENCY MODE, THE RELAY WILL GO TO ON WHEN CONTACTS GO OPEN
A30	THE RELAY WILL GO ON, THEN TURN OFF AFTER 30 MINUTES
A60	THE RELAY WILL GO ON, THEN TURN OFF AFTER 1 HOUR

Explanation of Level Meanings for Dimmer Modules

LEVEL	MEANING
100	THE DIMMER WILL TURN FULL ON
75	THE DIMMER WILL TURN ON 75%
50	THE DIMMER WILL TURN ON 50%
20	THE DIMMER WILL TURN ON 20%
10	THE DIMMER WILL TURN ON 10%
5	THE DIMMER WILL TURN ON 5%
1	THE DIMMER WILL TURN ON 1%
0	THE DIMMER FADES TO OFF

Programming LED Inputs for Scene Functions

Since the Low Voltage Relay Control Board has the ability to control multiple things from one button (a Scene), there may be an LED that corresponds to the Scene. This can be done instead of just having the Dimmer correspond to the Scene, which corresponds to the button location. Double press the Setup button and the Scene LED will turn on. Select the LED number desired to turn on with each Scene. Each Scene is done separately and each LED is set separately. See figures 12.1 through for visual description.

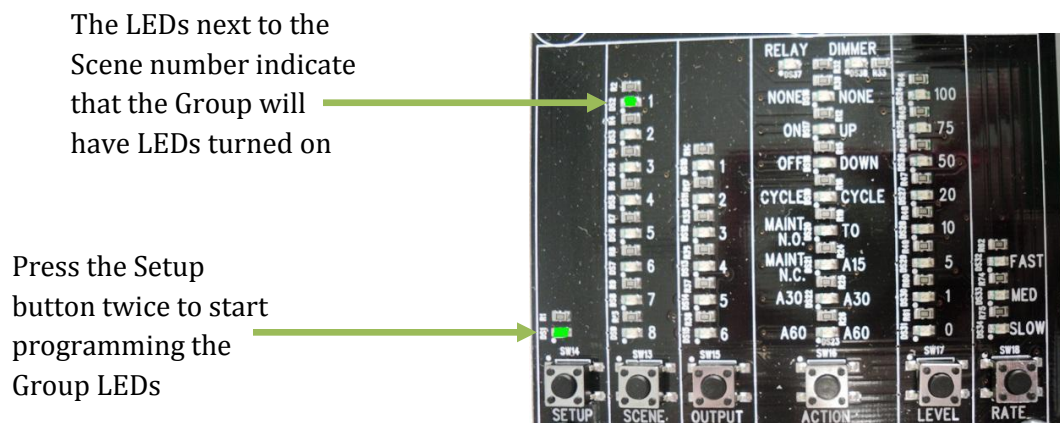

Figure 12.1

Wiring the High Voltage Connector Board (10137)

The High Voltage Connector Board (10137) connects to the low voltage relay control board via Transformer. The transformer connects the Low Voltage Control Board to the High Voltage Connector Board. The High Voltage Connector Board is wired from the circuit breaker panel with a Hot and Neutral feed for every Dimmer Module or Relay Pack.

Each Dimmer Module has a designated “Neutral” and “Hot” and Switch Leg. There will be 2 Switch Legs for every Dimmer Module. The order for the wires from the breaker panel is: “Neutral”, “Hot”, “Switch Leg”, and Switch Leg”. This order is for every Dimmer Module in the panel. See figure 13.1 for visual description. Once the High Voltage Connector board is wired, bring power to the system. Programming the Low Voltage Control Board can be done at this point.

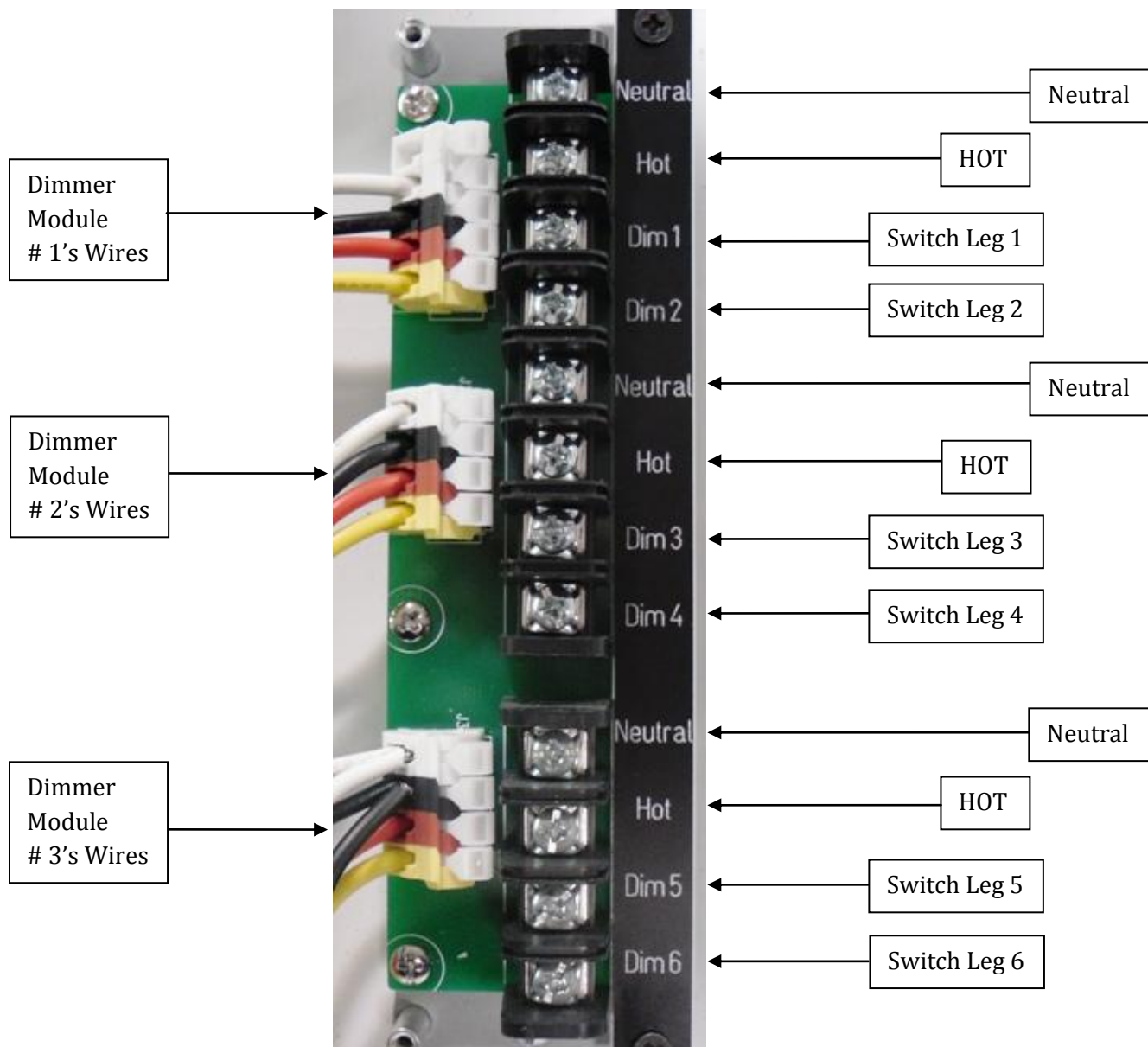

Figure 13.1

Frequently Asked Questions

1. Grouping – What is it?
 - a. Grouping allows for one button on a switch to control multiple relays.
 - i. Ex. In most kitchens there are lights over island, over counters, maybe above or under cabinets, maybe an eat-in nook area. If it is desired that most or all lights should turn on at the same time with the push of one button, Grouping makes this possible.
 - ii. “Welcome Home” is a desired feature with every home. Creating a Scene that includes the front exteriors, the garage lights, the foyer light and any other lights that create a warm, safe welcome accomplishes this desire.
 - iii. Going to bed at night is one of the perfect reasons to create a “Goodnight” Scene, making all lights go to OFF, or to glow levels.
2. What are the “Other Functions”?
 - a. Other functions indicate whether the system is a DMX slave or a standalone system. The numbers mean the following.
 - i. 1 – DMX Slave
 - ii. 2-7 – Not Used
3. What is the RS 485?
 - a. The RS 485 allows the system to be networked to a Time-Keeper®. The switches mean the following.
 - i. A – Pull Up (S)
 - ii. B – Pull Down (-)
 - iii. A B Termination (+)
4. What does “DMX Address” mean?
 - a. These are DMX Addresses that are set. The numbers mean the following.
 - i. 1 – 1
 - ii. 2 – 2
 - iii. 3 – 4
 - iv. 4 – 8
 - v. 5 – 16
 - vi. 6 – 32
 - vii. 7 – 64
 - viii. 8 – 128
 - ix. 9 – 256
5. What does the “Pilot Intensity” mean?
 - a. It stands for how intense the LEDs are on the switches. The numbers stand for the following.1
 - i. 1 – Low
 - ii. 2 – Medium
 - iii. 1 & 2 - High

Warranty

Touch-Plate® warrants this hardware product against defects in materials or workmanship, under normal use for a period of ONE (1) year from date of shipment. If a hardware defect is to arise and a valid claim is received within the Warranty Period, Touch-Plate® will repair or replace the product at no charge.

This warranty does not apply to:

- a. Damage to unit(s) caused by accident, acts of God, inappropriate installation, faulty installation, or any negligent use;
- b. Unit(s) which have been subject to being taken apart or otherwise modified;
- c. Unit not used in accordance with instructions;
- d. The finish on any portion of the product, such as surface and/or weathering, as this is considered normal wear and tear;
- e. Non-Touch-Plate hardware installed by the user;
- f. Damage caused by Non-Touch-Plate products;
- g. Damage caused by operating the product outside the permitted or intended uses described by Touch-Plate®;
- or
- h. Specific plans or Specific application requirements, unless the plans and specifications have been forwarded to Touch-Plate and Touch-Plate has approved and accepted the plans in writing.

EXCEPT AS PROVIDED IN THIS WARRANTY, TOUCH-PLATE IS NOT RESPONSIBLE FOR DIRECT, SPECIAL, INCIDENTAL, OR CONSEQUENTIAL DAMAGES RESULTING FROM ANY BREACH OF WARRANTY OR CONDITION, INCLUDING BUT NOT LIMITED TO, INSTALLATION OR REPLACEMENT LABOR COSTS.

Other Important Information

1. If your product is capable of storing data, you should make periodic backup copies of the information contained to protect the contents as a precaution.
2. Do not install hardware in environments that have a temperature range of 0-60°C, as this could shorten the life span of the hardware.