

# Touch-Plate® Lighting Controls

Control Plus Series – DMX III

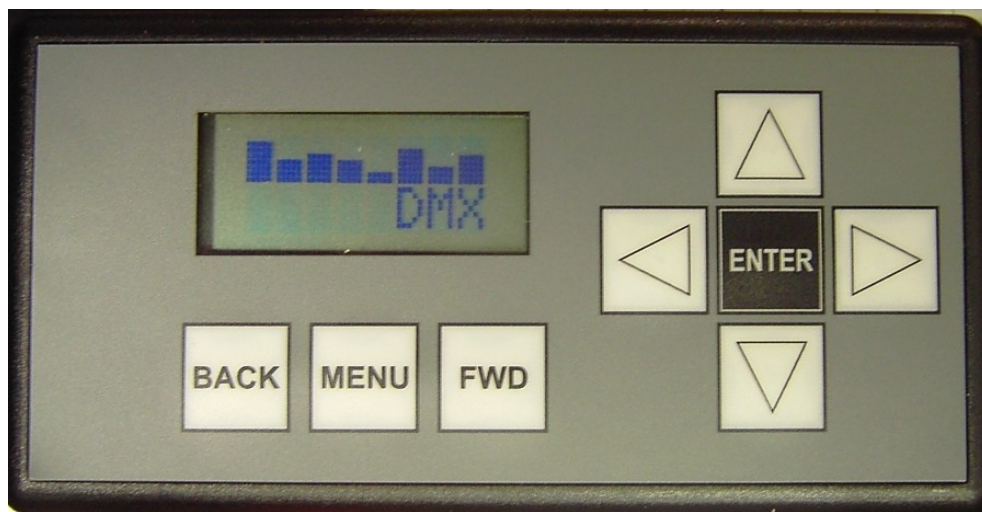

## *Control Plus Series DMX III Manual*

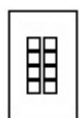

**Touch-Plate® Lighting Controls**

1830 Wayne Trace  
Fort Wayne, IN 46803

Phone: 260-426-1565  
Fax: 260-426-1442

Customer Service Email: [help@touchplate.com](mailto:help@touchplate.com)  
World Wide Web: <http://www.touchplate.com>

ol

## TABLE OF CONTENTS

|      |  |    |
|------|--|----|
| I.   | PREFACE .....                              | 2  |
| II.  | OVERVIEW .....                             | 3  |
| III. | DESCRIPTION .....                          | 4  |
|      | A. Relays ....                             | 5  |
|      | B. Power Supply .....                      | 6  |
|      | C. Master Board .....                      | 7  |
|      | D. Slave Board .....                       | 8  |
|      | 1. Inputs .....                            | 9  |
|      | 2. Outputs .....                           | 10 |
|      | a. Pilot Lights .....                      | 10 |
|      | b. Relays .....                            | 10 |
|      | E. Keypad .....                            | 11 |
|      | 1. Button Descriptions .....               | 12 |
|      | a. Back .....                              | 12 |
|      | b. Clear .....                             | 12 |
|      | c. Enter .....                             | 12 |
|      | d. Left/Right .....                        | 12 |
|      | e. Up/Down .....                           | 12 |
|      | 2. Input Functions .....                   | 13 |
|      | a. On .....                                | 13 |
|      | b. Off .....                               | 13 |
|      | c. Cycle .....                             | 13 |
|      | d. Maintain NO/NC .....                    | 13 |
|      | e. Blk Warn .....                          | 13 |
|      | f. Flash .....                             | 13 |
|      | g. A-Off 15, 30, 1H, 2H .....              | 13 |
| IV.  | INSTALLATION .....                         | 14 |
|      | A. Planning .....                          | 14 |
|      | 1. Pilot Light Wiring .....                | 14 |
|      | 2. Switch Wiring .....                     | 14 |
|      | 3. DMX RS-485 Wiring .....                 | 14 |
|      | B. Enclosure .....                         | 15 |
|      | C. Control Plus DMX Power Connection ..... | 15 |
|      | D. Electrical Connections .....            | 16 |
|      | 1. High Voltage .....                      | 16 |
|      | 2. Power Supply .....                      | 17 |
|      | 3. Direct Operation Of Relays .....        | 17 |
|      | 4. Connecting The Control Wires .....      | 17 |
|      | 5. Running Control Wires .....             | 17 |
|      | 6. Inputs .....                            | 18 |
| V.   | SPECIFICATIONS .....                       | 18 |
|      | A. Enclosure .....                         | 18 |
|      | B. Relay (Model 4000-PL) .....             | 18 |
|      | C. Transformer .....                       | 18 |

# I. PREFACE

This manual contains all the information necessary to install and start the Control Plus DMX III 08 through 48 lighting control panels.

## Typical System Layout

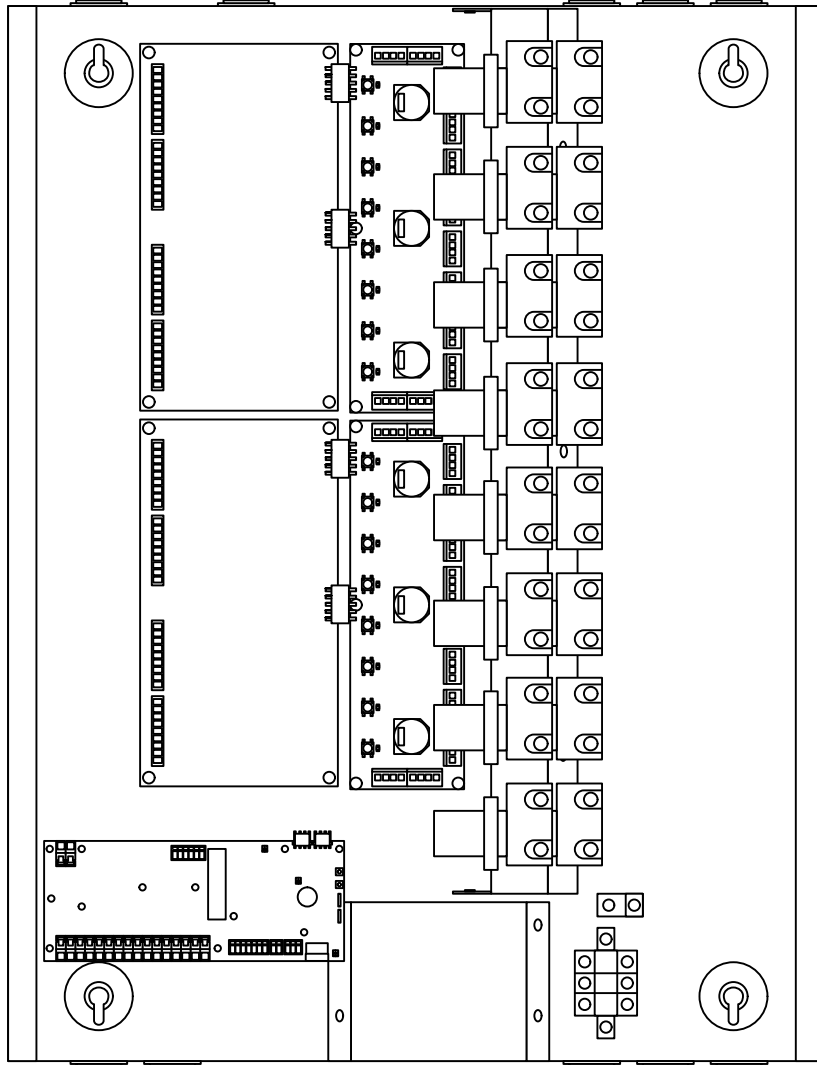

*Figure I-1 Typical Layout for DMX Deluxe System*

## II. OVERVIEW

The Control Plus DMX III is the best programmable low-voltage control panel on the market. The panels are economical, versatile, and easy to operate.

### **DMX Standard System features:**

- Up to 48 loads are controlled individually
- Each load can be controlled by on/off momentary action switches or by maintained contact switches.
- All switch input actions override previous commands.
- Completely modular design and assembly.
- Graphic display panels, LED type, which show the status of each relay, can be used with the Control Plus Series DMX III.
- Loads can be controlled from many locations via low-voltage #22 AWG wire.
- The relay panels are powered by 120 VAC.
- Easily interfaced with other systems in the building.
- Override buttons for each relay located directly on the control boards.
- Can be incorporated with occupancy sensors and photocells.

### **In addition to the above the DMX Deluxe System also features:**

- DMX/Soft Patch Matrix allows any input to control any or all outputs. Soft Patch also allows the same input to have different control functions per output, within the variety of input control functions. (See list of functions on page 13)
- All I/O connectors are depluggable.
- Sixteen programmable inputs and outputs per Control Plus Series DMX III control board.
- A group of loads can be controlled by on/off momentary action switches or by maintained contact switches.
- Up to 48 loads can be controlled individually or in groups

### III. DESCRIPTION

#### **DMX Standard Panel Contains:**

Each panel contains a Transformer, a master board, programming keypad, a control board for every eight relays, and relays. These components are mounted in an UL approved enclosure.

#### **DMX Deluxe Panel Contains**

Each panel contains a Transformer, a master board, an I/O card, programming keypad, a control board for every eight relays, and relays. These components are mounted in an UL approved enclosure.

\*The relays are connected to the control boards by push-in connectors.

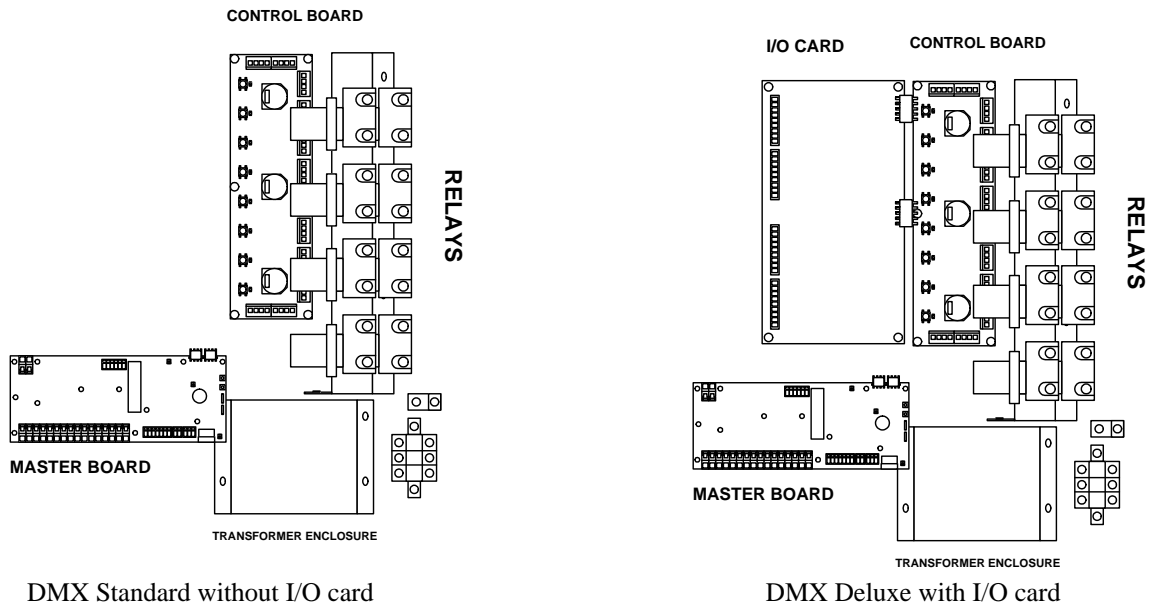

*Figure III-1 System Layout*

## A. Relays

The panels use the Touch-Plate 4000-PL relay. This relay can switch loads rated to 20 amps at 277 VAC Tungsten or Ballast (and 347VAC for Canada). A secondary contact is provided for use with pilot lights.

When the relay is operated, it changes state, from off to on or vice versa and mechanically latches in that state. No holding current is required. As a result, heat in the enclosure is minimized.

The secondary contact is used to illuminate lighted switches, light indicators in graphic panels, and other devices. It is also used to provide a status output for the control board. The status output can be used by a computer and other devices.

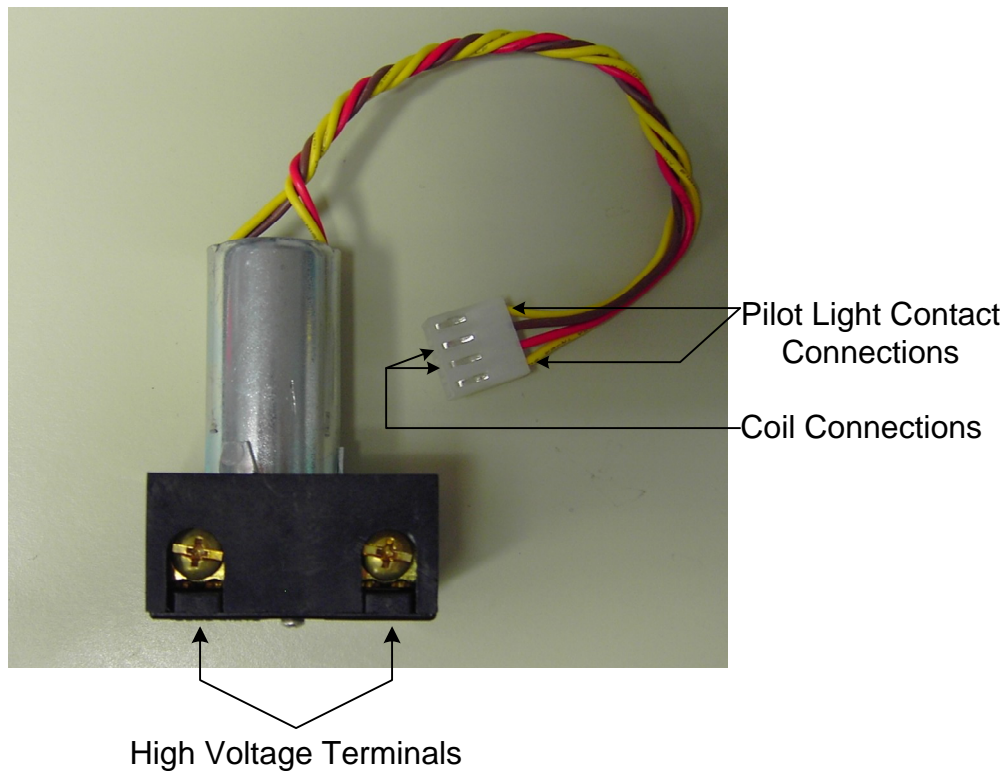

*Figure III-2 Touch-Plate Relays*

## B. Power Supply

The primary feed of the transformer is 120 VAC (Black). The white wire is Neutral. The transformer supplies the DMX Master Board with 24 VAC. The transformer attaches to the two-pin connector on the Master Board.

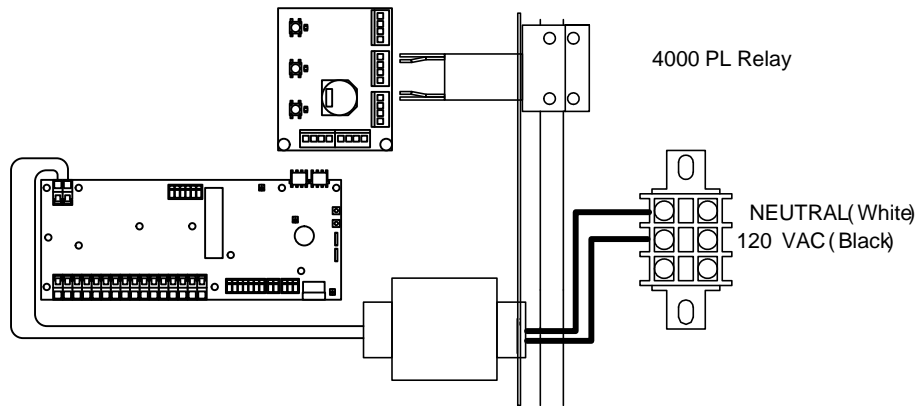

*Figure III-3 Transformer Power Supply*

## C. Master Board

The DMX Master Board is the brain for the rest of the panel. The keypad connects directly into the Master Board through a thirty-pin connector. The sixteen inputs on the top side of the board are programmed by the keypad.



*Figure III-4 Soft Patch Master Board*

## D. Control Board

The Control Board has eight relay outputs on the right. Along the left are eight pilot light feedback outputs with individual relay override buttons.

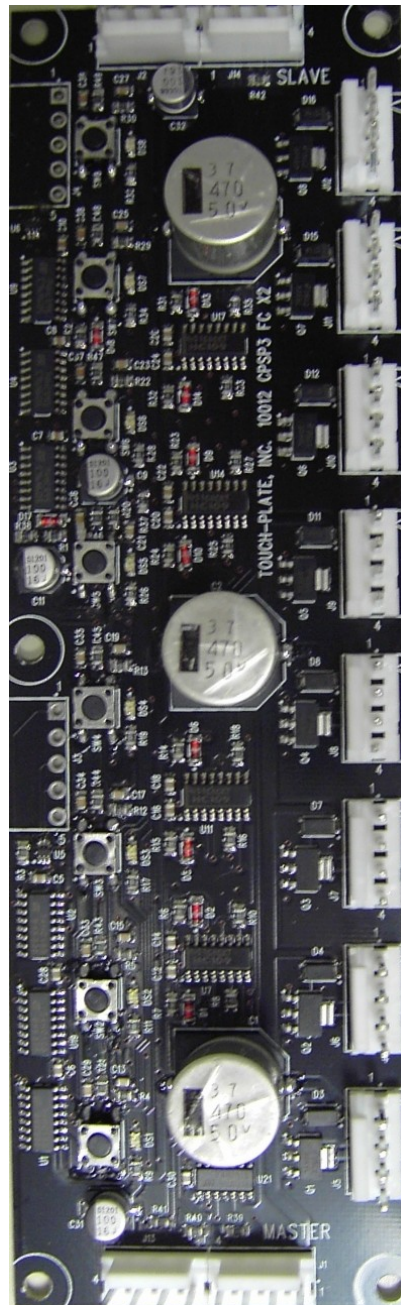

*Figure III-5 Soft Patch Control Board*

## 1. Inputs

In some DMX applications an I/O card is needed. There are sixteen input and sixteen output terminals on each I/O card in the panel. A precision flathead screwdriver is best used to attach wires to the I/O card terminal blocks.

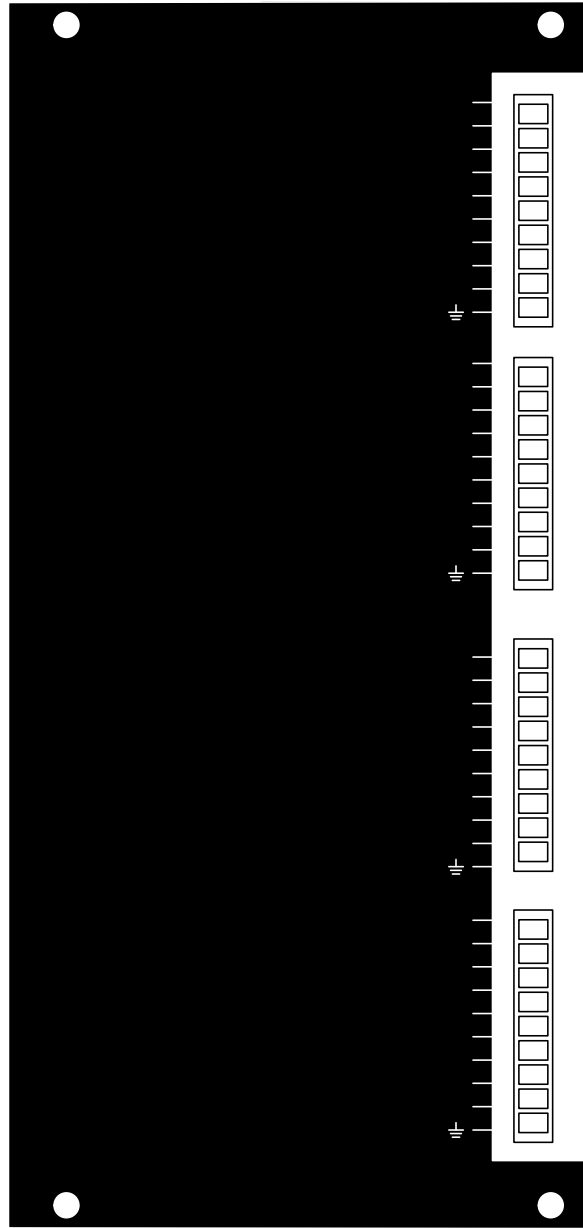

*Figure III-6 Quick Connect Terminals*

## 2. Outputs

### a. Pilot Lights (only when I/O card is present)

Allows for Pilot Light feedback to the switch to identify if the load is ON or OFF. The L.E.D. output voltage is regulated to thirty-four VDC.

### b. Relays

Provides the high voltage switching capabilities for the loads. In addition, they provide auxiliary contacts to give L.E.D. indication on the circuit boards.

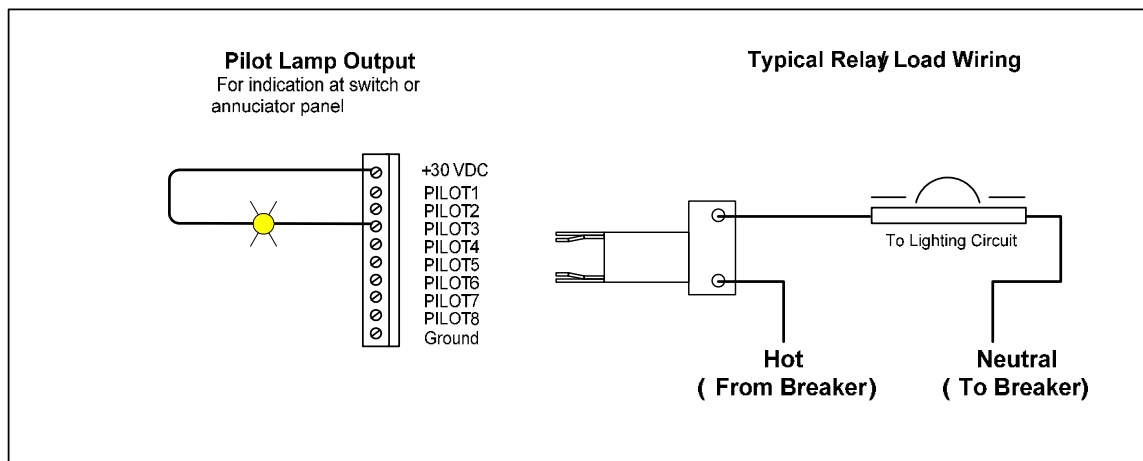
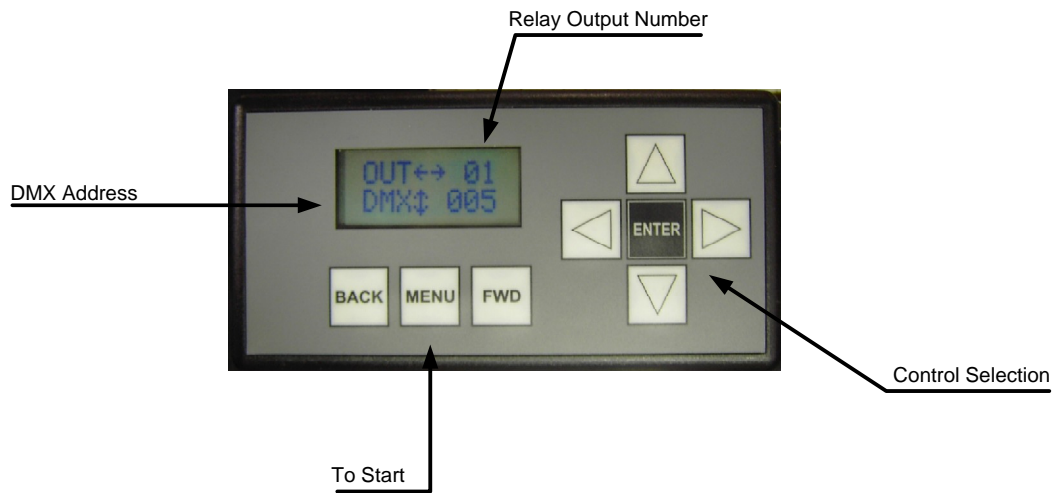

Figure III-7 Pilot Lamp Wiring Diagram

Figure III-8 Relay Wiring Diagram

## E. Keypad

The DMX Keypad allows the operator to program the inputs to do whatever is needed. The keypad has a total of seven push buttons and a LCD display. The thirty-pin connector mates the Keypad to the DMX Master Board.



*Figure III-9 DMX Keypad Deluxe mode*

# 1. DMX-III Keypad Operations



- Use the button labeled **MENU** to scroll through the menu options.
- Use the **BACK** button to exit out of any menu and return to the status display.
- Use the **ENTER** button to select a menu option or set a variable.
- The arrow keys (**LEFT, RIGHT, UP, DOWN**) are used to select an input, SP (DMX) channel or relay.

## DMX Standard Keypad Menus

Using the **MENU** button, scroll through the menu options. Press **ENTER** to select an option.

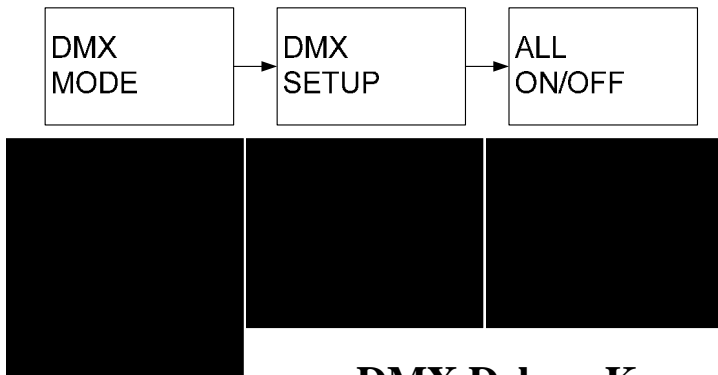

## DMX Deluxe Keypad Menus

Using the **MENU** button, scroll through the menu options. Press **ENTER** to select an option.

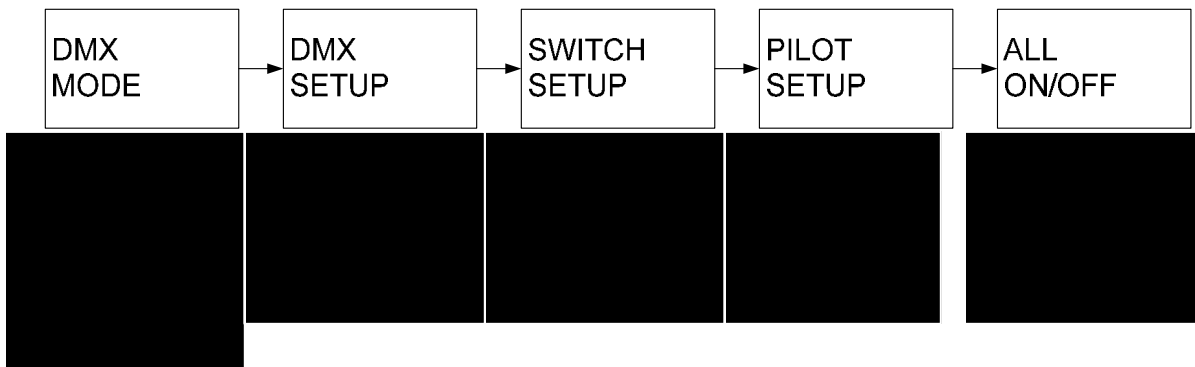

## **2. Input Functions for DMX Deluxe mode only**

### **a. On**

This enables you to switch the programmed outputs (relays) to the ON state with one touch of the input (button), and won't change the ON relays OFF.

### **b. Off**

This enables you to switch the programmed outputs (relays) to the OFF state with one touch of the input (button), and won't change the OFF relays ON

### **c. Cycle**

This enables you to switch a single relay, or multiple relays as a zone, ON and OFF with the same input. If one or more relays in a zone are overridden to an opposite state, the Master Controller will keep all relays in the zone in synch by monitoring the status of each relay as well as the commands to the Input.

### **d. MAINT NO / MAINT NC**

NO- This input is activated when the switch input is closed and opened when the switch contact is open. (commonly used for photocells and motion sensors)

NC- This input is activated when the switch input is open and closed when the switch contact is closed.

### **e. BWarn (Blink Warn)**

This option gives a blink warn to the input five minutes before the actual output will go OFF. When this Input signal is given, the output goes OFF for one second, then back to ON. Five minutes later the output goes OFF unless an input is touched which is assigned to the same output. This will prevent the OFF command.

### **f. Flash**

This input is used for security purposes. It will Flash the programmed relays at 1 second intervals, ON and OFF. For use with security systems, motion sensors, and smoke detectors.

### **g. A-Off 15, 30, 1H, 2H (Auto Off)**

This enables you to set the input to the desired Auto Off time. When you activate the input, the relay turns ON, and then will turn OFF in the programmed amount of time. The times can be set to the following: 15 minutes, 30 minutes, 1 hour, 2 hours

## IV. INSTALLATION

The Control Plus Series is easy to install and connect. It is also easy to adapt to the user's needs.

### A. Planning

Because of the flexibility of the Control Plus DMX, it is all too tempting to skip details in planning and installation. You can save a lot of time, however, by carefully considering the needs of your installation before you start to work.

The following matters should be taken into consideration in planning your installation:

#### 1. Pilot Light Wiring

The LED output section of the CPSP-III is meant to handle LED's not incandescent outputs. 22-gauge wire is normally used. DO NOT USE wire heavier than 18 gauge due to wire entry limitations of the terminal blocks.

Use a single thicker wire or several wires in parallel, for the pilot common wire.

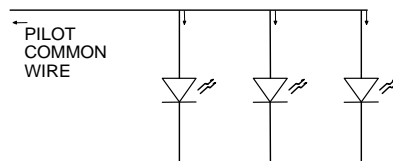

Figure IV-1 Pilot Light Wiring

#### 2. Switch Wiring

Since the switch wires carry very little current, 22-gauge wire can be used. A minimum of 22-gauge wire is necessary to ensure that the wire is strong enough to be pulled through conduits and other tight spaces.

Use 22-gauge wire for distances of up to 3,000 feet. Longer distances require thicker wire. Use shielded wire for long runs in areas with strong radio signals.

#### 3. DMX RS-485 input wiring

Take the DMX network control wire and connect them into the RS-485 plug as shown

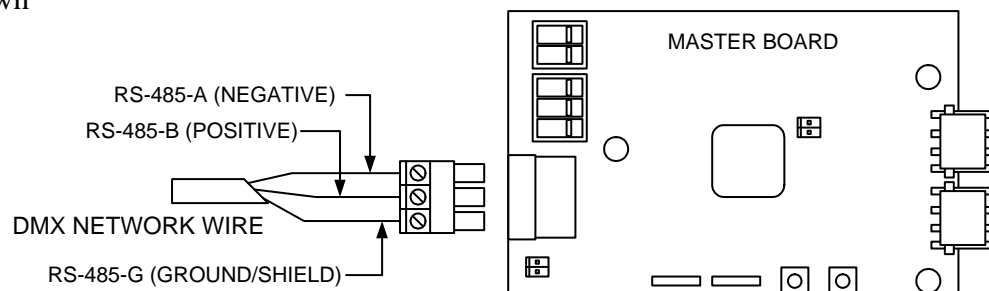

## B. Enclosure

The enclosure contains the Transformer, the control boards, and the relays. To install these components, first remove the enclosure door.

Place the enclosure against the wall and secure it with four screws. Then reinstall the door.

### IMPORTANT!

*Never work on system when the power is on. Any work done on the Control Plus Series when the power is on will void the warranty. Before reconnecting the power, check all the connections.*

## C. Control Plus DMX Power Connection

Control Plus DMX panels require their own circuit breakers to prevent unrelated overloads or short circuits.

When working with a Control Plus DMX panel, turn the corresponding circuit breaker off.

\*It is recommended to use surge protection and/or an Uninterruptible Power Supply to help prevent damage to the control panel.

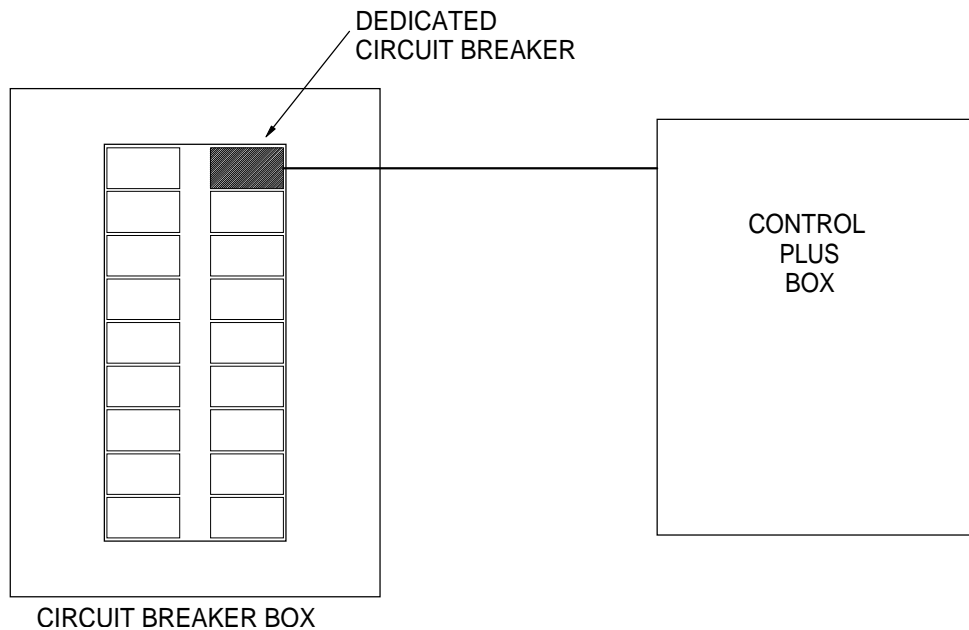

Figure IV-2 Circuit Breaker

## D. Electrical Connections

### 1. High Voltage

One of the terminal screws on each relay should be connected to 120 or 277 VAC. (The voltage varies with the item being controlled).

Power to the relays must come via a circuit breaker. The circuit breaker must not be rated for more than 20 amps, which is the relay's maximum rating.

The connected load to each relay should not be more than that specified by the electrical code for your area.

The power from one breaker can be spread out over more than one relay as long as the above requirements are met.

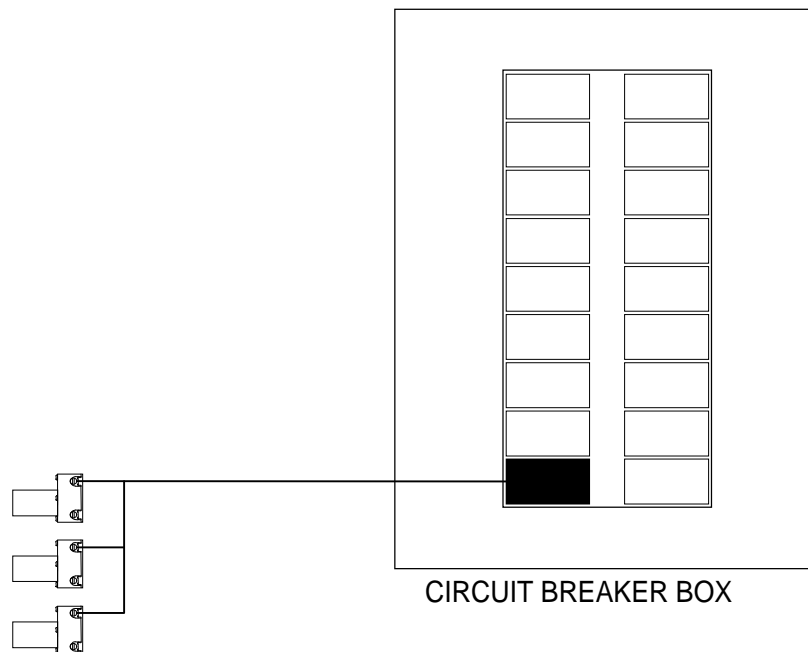

Figure IV-3 Relay HV Connection

The relay screw terminals can accept up to two #10 AWG copper wires. Be sure not to exceed the maximum current that can be carried by this conductor size according to the local electrical codes.

If two wires are inserted into one of the relay terminals, they should not differ by more than one wire size. Otherwise the pressure on the smaller wire will be reduced, thus preventing a good electrical contact.

Use 25-pound inch torque on the screws.

**NOTE:** Make sure load power at the circuit breaker is *off* before connecting any loads to the relay.

## 2. Power Supply

Connect the panel to its own circuit breaker. Use the 120 VAC terminal connection.

Make sure that the panel has not been damaged during shipment. Turn on the circuit breaker. The relays should be set in the on position, so all the LED's on the power and control boards should be on.

Check the following points:

- When power is turned on, no relay should change state. If a relay cycles when power is turned on, make sure that the transistor in front of the relay is cool to the touch. (Be careful! If the transistor is hot, it could be *very* hot.) If it is hot, unplug the relay because the transistor is bad.
- Make sure that no LED is brighter than any other LED. If one is brighter, unplug the associated relay, because it is more than likely bad. See the troubleshooting chapter for instructions on testing relays.

## 3. Direct Operation Of Relays

To operate the relay directly, press the manual override buttons on the relay control card.

## 4. Connecting The Control Wires

After all the relays are on, the lights can be controlled using their corresponding circuit breakers. Switch off the power to the Control Plus DMX so that you can safely make the necessary low voltage I/O connections. The warranty is voided if the I/O wires are connected with power on.

## 5. Running Control Wires

**IMPORTANT!** *Never run control wires in the same conduit with high voltage wiring (110, 240, 277 AC or higher) even if the building code permits it.*

In long conduits, control wires running next to current-carrying conductors can induce sufficient voltage in the switch wires to cause random switching, bad circuit boards and, in extreme cases, burned out transistors and relays.

## 6. Inputs

Inputs are wired as shown in the earlier diagrams. One side of the switch must be connected to a switch common terminal on the board; the other side must be connected to the relevant switch input on the I/O boards.

## V. Specifications

### A. Summary Of Features & Dimensions

| DMX Standard  | Master Boards | I/O Cards | INPUTS (when available)   | MASTER CONTROL | OUTPUTS HI-V | OUTPUTS LO-V | DIMENSIONS L W D     |
|---------------|---------------|-----------|---------------------------|----------------|--------------|--------------|----------------------|
| DMX-III -0008 | 1             | 0-1       | 8- Cycle<br>8- Maintain   | YES            | 8            | 0-16         | 15" x 15" x 5.25"    |
| DMX-III -0016 | 1             | 0-2       | 16- Cycle<br>16- Maintain | YES            | 16           | 0-32         | 23.25" x 18" x 5.25" |
| DMX-III -0024 | 1             | 0-3       | 24- Cycle<br>24- Maintain | YES            | 24           | 0-48         | 34.25" x 18" x 5.25" |
| DMX-III -0032 | 1             | 0-4       | 32- Cycle<br>24- Maintain | YES            | 32           | 0-64         | 44" x 20" x 5.25"    |
| DMX-III -0040 | 1             | 0-3       | 24- Cycle<br>16- Maintain | YES            | 40           | 0-48         | 44" x 20" x 5.25"    |
| DMX-III -0048 | 1             | 0-2       | 16- Maintain              | YES            | 32           | 0-32         | 44" x 20" x 5.25"    |

| DMX Deluxe    | Master Boards | I/O Cards | PROGRAMMABLE INPUTS (when available) | MASTER CONTROL | OUTPUTS HI-V | OUTPUTS LO-V | DIMENSIONS L W D     |
|---------------|---------------|-----------|--------------------------------------|----------------|--------------|--------------|----------------------|
| DMX-III -0008 | 1             | 0-1       | 16-32                                | YES            | 8            | 0-16         | 15" x 15" x 5.25"    |
| DMX-III -0016 | 1             | 0-2       | 16-48                                | YES            | 16           | 0-32         | 23.25" x 18" x 5.25" |
| DMX-III -0024 | 1             | 0-3       | 16-64                                | YES            | 24           | 0-48         | 34.25" x 18" x 5.25" |
| DMX-III -0032 | 1             | 0-4       | 16-80                                | YES            | 32           | 0-64         | 44" x 20" x 5.25"    |
| DMX-III -0040 | 1             | 0-3       | 16-64                                | YES            | 40           | 0-48         | 44" x 20" x 5.25"    |
| DMX-III -0048 | 1             | 0-2       | 16-48                                | YES            | 32           | 0-32         | 44" x 20" x 5.25"    |

*Figure V-1 Summary of Features and Dimensions*

#### RELAY (Model 4000-PL)

S.P.S.T. Mechanically Latching Main Contact:

1.0 h.p. at 125VAC

1.5 h.p. at 250VAC

20 amps at 125VAC or 277VAC (347VAC CSA Listed)

(Tungsten and Ballast)

Auxiliary contact: 1 amp at 6.3VAC

#### TRANSFORMER

Primary Input:

120VAC

Secondary Output:

24VAC at 0.48 amps

This document was created with Win2PDF available at <http://www.win2pdf.com>.  
The unregistered version of Win2PDF is for evaluation or non-commercial use only.  
This page will not be added after purchasing Win2PDF.