

Touch-Plate[®] ***Lighting Controls***

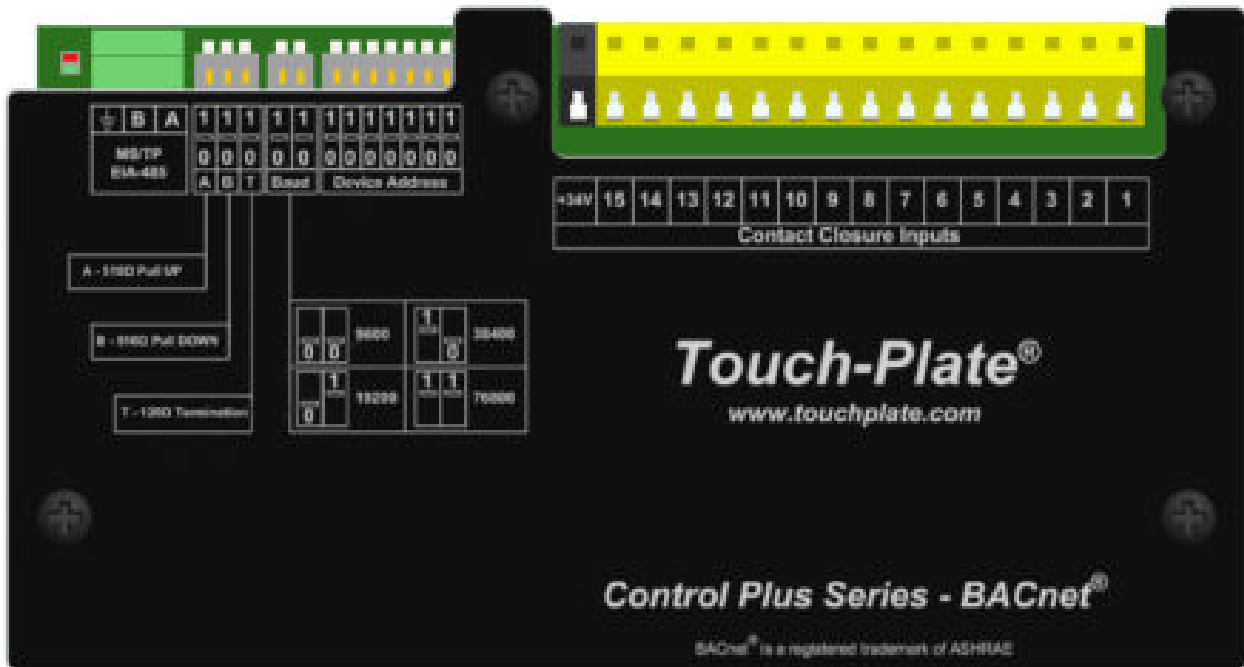

Control Plus Series ***BACnet***[®] ***Relay Control Panels***

Touchplate Technologies, Inc.
1830 Wayne Trace
Fort Wayne, IN 46803

Phone: 260-426-1565
Fax: 260-426-1442
Web: www.touchplate.com

Table Of Contents:

Cover Page	Cover
T.O.C.	i
System Overview	1
System Specifications	2
Ordering Guide and Part Numbers	3
BACnet Objects Summary	4 & 5
Panel Detail	6
System Communication Details	7
LED & Switch Wiring	8
BACnet Addressing	9 & 10
BACnet Override Switch Operation Details	11
P.I.C. Statement	12
Panel Dimensions	13
Mechanical Mounting Detail	14

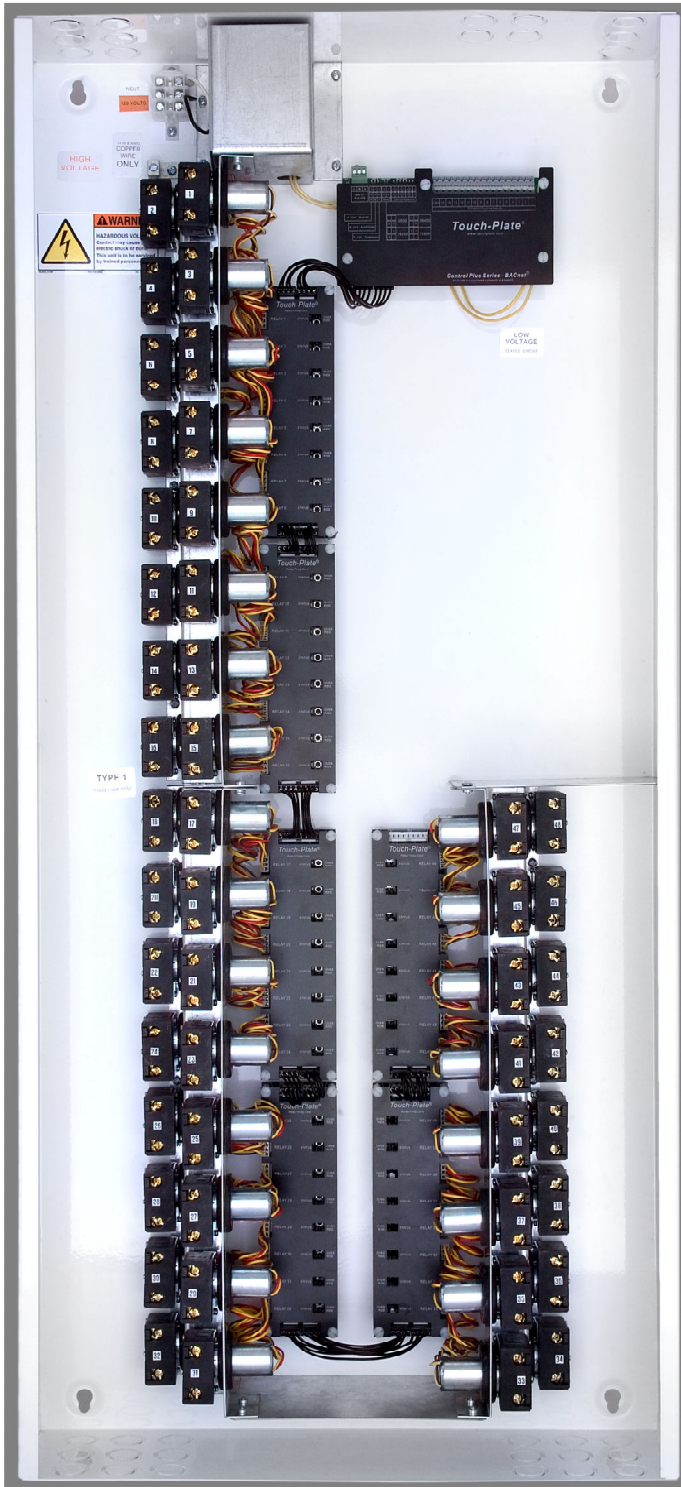

Overview:

The Control Plus Series (CPS)-BACnet lighting control panels are designed to meet a vast majority of applications requiring ON/OFF control of the light system.

The CPS-32-48-BAC-M and the CPS-32-48-BAC-E are pre-assembled lighting control panels that contain 32, 40, or 48 mechanically latching relays rated for 20 amp lighting loads at 120, 220, 277, and 347 VAC.

The CPS-BACnet lighting control panels can integrate to any building automation system that supports BACnet communication protocol through an integral MSTP Port.

Features:

- Factory Pre-Assembled and Tested
- Single Pole, 20 Amp 120, and 277 VAC Lighting Relays (347 VAC Canada)
- Feed-through configuration
- Accepts Momentary and Maintained Switch Inputs
- Integral MSTP Communication Port
- Configurable Baud Rate – 9600/19200/38400/76800
- Configurable MS/TP Address and Device ID
- Easy to Install and Start-Up; No programming skills required

Specifications:

Power

- Transformer Input Power: 120VAC
- Requires dedicated feed to power main controller

Communication / Protocol

- BACnet MS/TP Communication Port
- Configurable Baud Rate – 9600/19200/38400/76800 (via Dip Switch)
- Configurable MS/TP Address – (0-127, via Dip Switch)
- Configurable Device ID – (via software)

Inputs

- 15 Contact Closure Inputs, each represented as 2 Binary input objects
- Binary Inputs Objects 1 – 15 are Momentary
- Binary Inputs Objects 101 – 115 are Maintain

Environment

- Operating Temperature: 0-65°C (32-145°F)
- Humidity: 10%-90% (non-condensing)

Standard

- UL Listed

Relays

- Up to 48 Relays, each represented as a Binary output
- Mechanical Latching Relay; Relays maintain On/Off state during power failures
- Relays rated for 20A continuous use, which exceeds continuous load allowed for 20A Overcurrent Protection Device (Circuit Breaker)

Load Types

- Incandescent (Tungsten) and Halogen
- Magnetic Low Voltage
- Electronic Low Voltage
- Neon or Cold Cathode
- Magnetic and Electronic Fluorescent Ballast
- H.I.D.
- 1.0 HP Motor Load @ 125VAC
- 1.5 HP Motor Load @ 250VAC

CPS BACnet® Relay Panel Ordering Guide

Relay Panel	Number of Relays	Inputs / Outputs
CPS-08-BAC-EX	8 20A Relays (4000-PL)	16 Inputs / 16 Outputs *
CPS-16-BAC-EX	16 20A Relays (4000-PL)	32 Inputs / 32 Outputs *
CPS-24-BAC-EX	24 20A Relays (4000-PL)	48 Inputs / 48 Outputs *
CPS-32-BAC-EX	32 20A Relays (4000-PL)	48 Inputs / 48 Outputs *
CPS-40-BAC-EX	40 20A Relays (4000-PL)	32 Inputs / 32 Outputs *
CPS-48-BAC-EX	48 20A Relays (4000-PL)	32 Inputs / 32 Outputs *
CPS-08-BAC-M	8 20A Relays (4000-PL)	16 Inputs
CPS-16-BAC-M	16 20A Relays (4000-PL)	16 Inputs
CPS-24-BAC-M	24 20A Relays (4000-PL)	16 Inputs
CPS-32-BAC-M	32 20A Relays (4000-PL)	16 Inputs
CPS-40-BAC-M	40 20A Relays (4000-PL)	16 Inputs
CPS-48-BAC-M	48 20A Relays (4000-PL)	16 Inputs
* Max number of Inputs and Outputs. Please specify total number of 10019 I/O cards needed when ordering. Example: CPS-32-BAC-E1 (I/O points come in multiples of 16)		

Relays

- Each relay is represented as a binary output.

BO1 = Relay 1
BO2 = Relay 2
BO3 = Relay 3
.....
BO_n = Relay n

Write an enumerated value of 1 to the Present_Value property to turn the relay on.
Write an enumerated value of 0 to the Present_Value property to turn the relay off.

Digital Inputs

- Each input is represented as 2 binary inputs (momentary and maintain).
- Momentary inputs toggle on the rising edge of the input signal.
- Maintain inputs follow the level of the input signal. The object instance is offset by +100 from the momentary object for the same input.
- Max. voltage of 35VDC.
- Min. voltage of 20VDC to activate input.

BI1 = Input 1 (momentary)
BI101 = Input 1 (maintain)

BI2 = Input 2 (momentary)
BI102 = Input 2 (maintain)

.....
BI_n = Input n (momentary)
BI_n+100 = Input n (maintain)

Input state is stored in the Present_Value property (either 0 or 1).

Open Collector Outputs (CPS-XX-BAC-E only)

- Each output is represented as an analog value.
- Outputs are open collector, and do not source current.
- Max. voltage of 35VDC, max. current of 100mA, per output.
- Protection diodes (not provided) must be used when driving inductive loads.

AV1 = Open collector 1
AV2 = Open collector 2
.....
AV_n = Open collector n

Write an enumerated value of 0 to the Present_Value property to turn off the transistor (output goes into a high impedance state).

Write a non-zero enumerated value to the Present_Value property to turn on the transistor (output goes low). A value of 241 is suggested for consistency with the Consensio wall station.

Device Options

- Represented as an analog value.

AV100 = Device Options

The Present_Value property is bit-mapped as follows:

- Bit 0 – Setting this bit to 1 will allow infinite COV subscriptions.
Default value is 0.

Warm Boot

- Clears momentary input values.
- Turns off open collector outputs.
- Clears any relay overrides.
- Requires password of “clearunit”.

Cold Boot

- Performs all warm boot items.
- Resets all items to factory defaults (including Device Instance ID).
- Requires password of “areyousure”.

Misc.

- Object names are limited to 19 characters.
- Up to 32 COV subscriptions are allowed.

Panel Details:

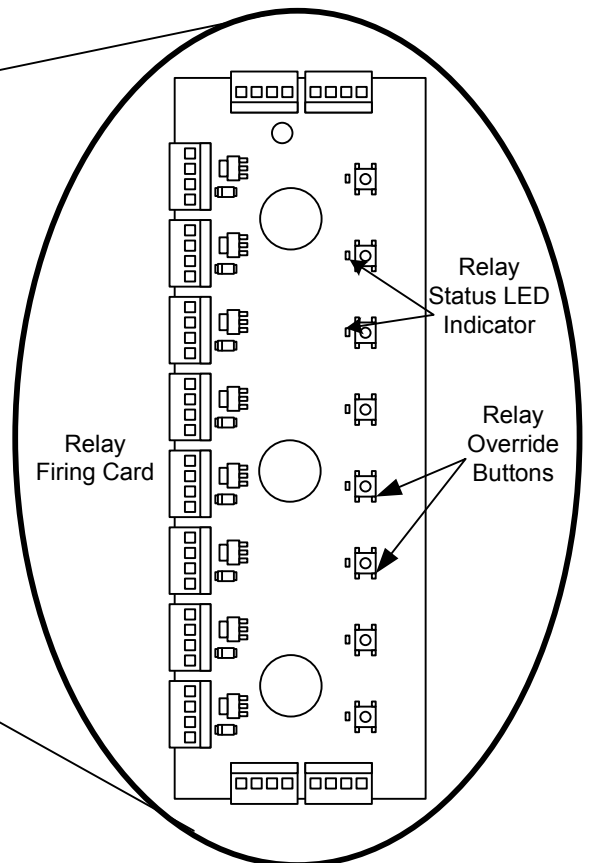
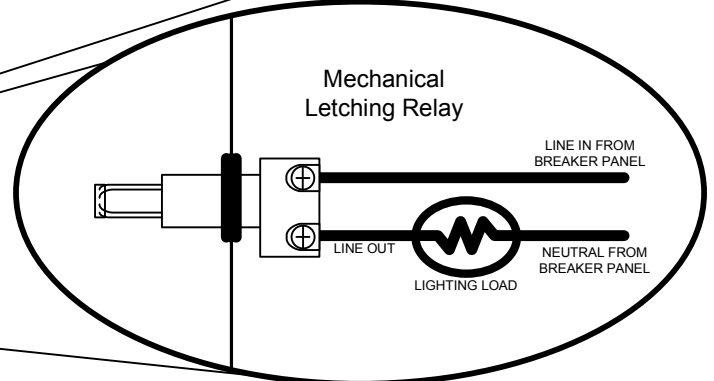
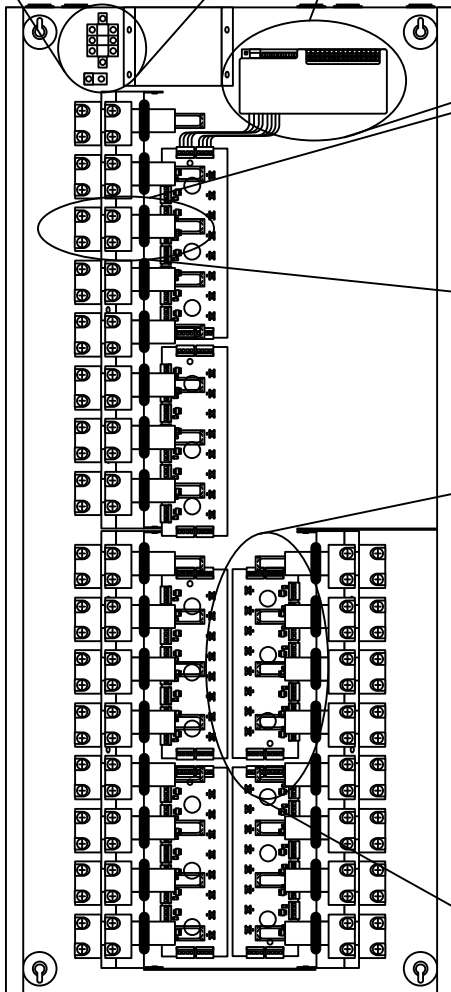
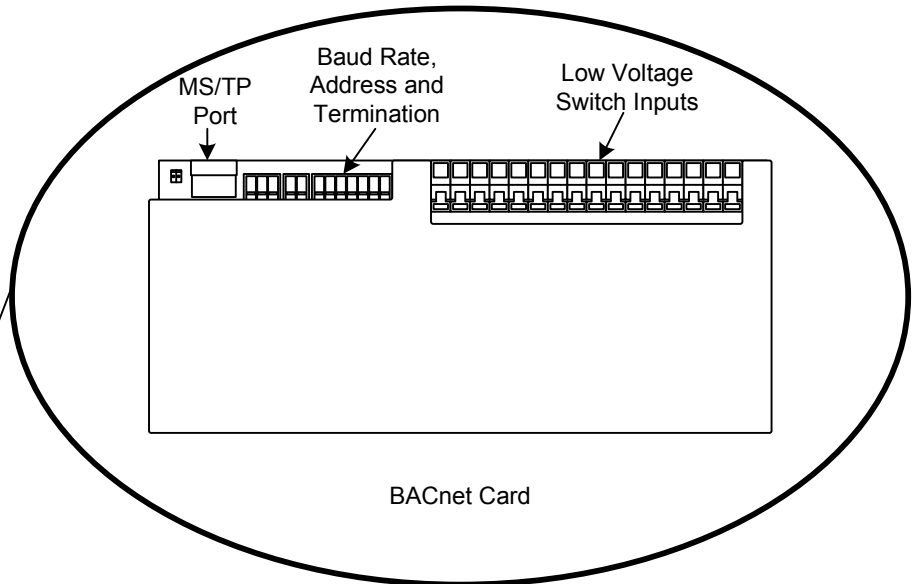
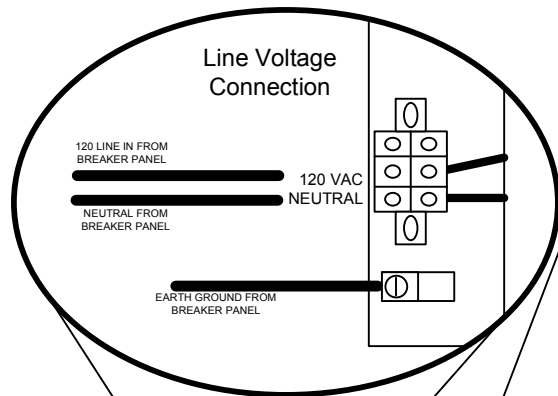

- Refer to Mechanical Sheet for Dimensions and Mounting Information
- Refer to Specifications Sheet for Line and Low Voltage Information

BACnet Card Details

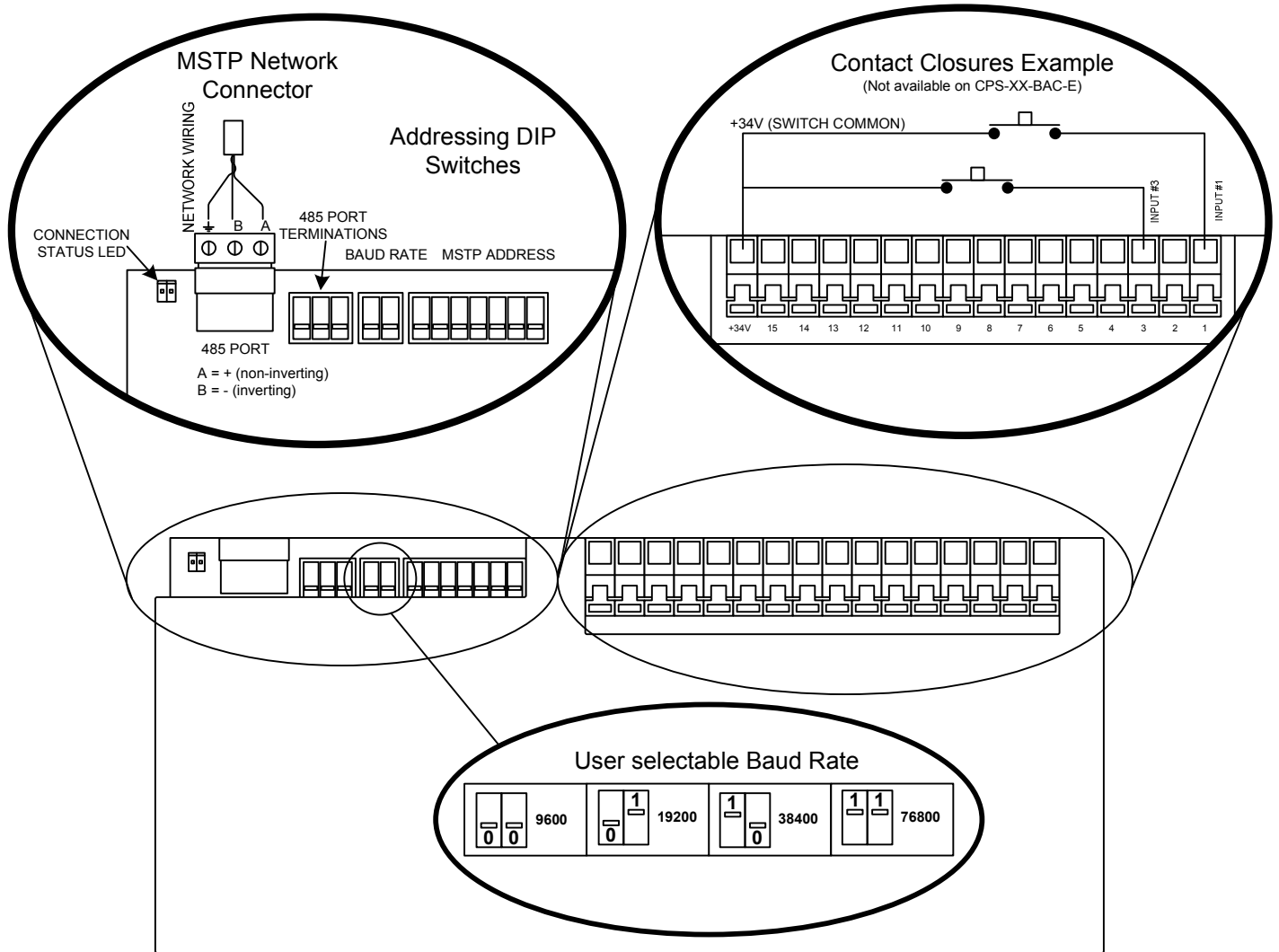

Card Configuration:

Contact Closure inputs must be fed from the +34v supply located on the left side of the “Contact Closures Switch Terminal”. Any type of dry contact closure is acceptable.

Some examples of dry contact closures are:

- Relay
- Push-Button Switch
- N.O. (Normally Open)
- N.C. (Normally Closed)

Network Termination:

There are 3 termination resistors for the 485 MSTP port. These resistors are connected using the 3 position dip switch located next to the green MSTP port connector. Each switch has a small number below it (1, 2, or 3). Switch 1 connects a 510 ohm pull up on the A (+ or non-inverting) input. Switch 2 connects a 510 ohm pull down on the B (- or inverting) input. Switch 3 connects a 120 ohm termination resistor between A and B.

Only one device on a MSTP cable run should have the pull up/pull down resistors (switches 1 & 2) activated.

The first device and the last device on a MSTP cable run should have the termination resistor activated (switch 3).

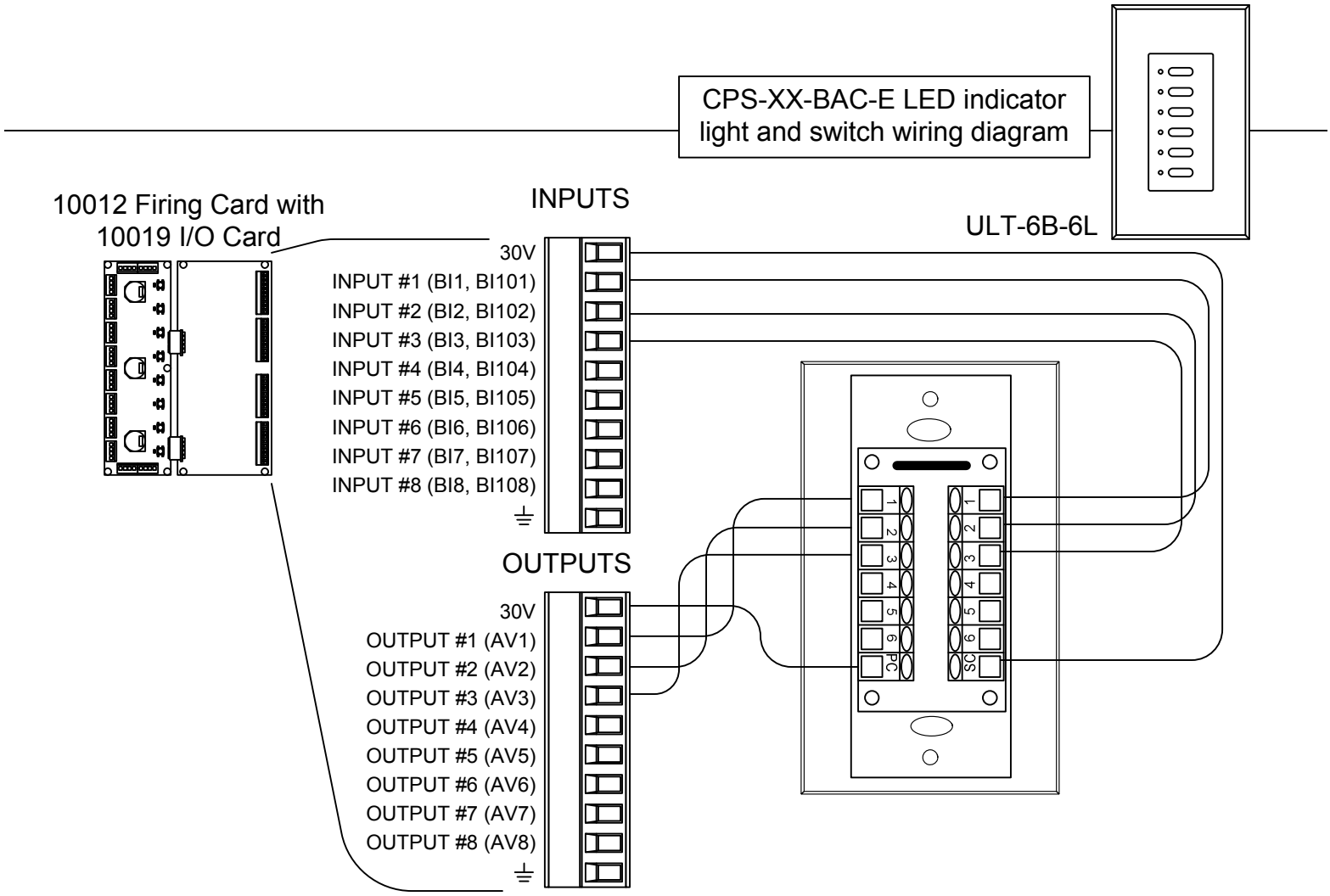

Addressing:

- To assign panels to an address, set switches as follows

Address #	Switch Setting	Address #	Switch Setting	Address #	Switch Setting
0		21		42	
1		22		43	
2		23		44	
3		24		45	
4		25		46	
5		26		47	
6		27		48	
7		28		49	
8		29		50	
9		30		51	
10		31		52	
11		32		53	
12		33		54	
13		34		55	
14		35		56	
15		36		57	
16		37		58	
17		38		59	
18		39		60	
19		40		61	
20		41		62	

Addressing:

- To assign panels to an address, set switches as follows.

Address #	Switch Setting	Address #	Switch Setting	Address #	Switch Setting	Address #	Switch Setting
63		84		105		126	
64		85		106		127	
65		86		107			
66		87		108			
67		88		109			
68		89		110			
69		90		111			
70		91		112			
71		92		113			
72		93		114			
73		94		115			
74		95		116			
75		96		117			
76		97		118			
77		98		119			
78		99		120			
79		100		121			
80		101		122			
81		102		123			
82		103		124			
83		104		125			

BACnet Override Switch Operation Details

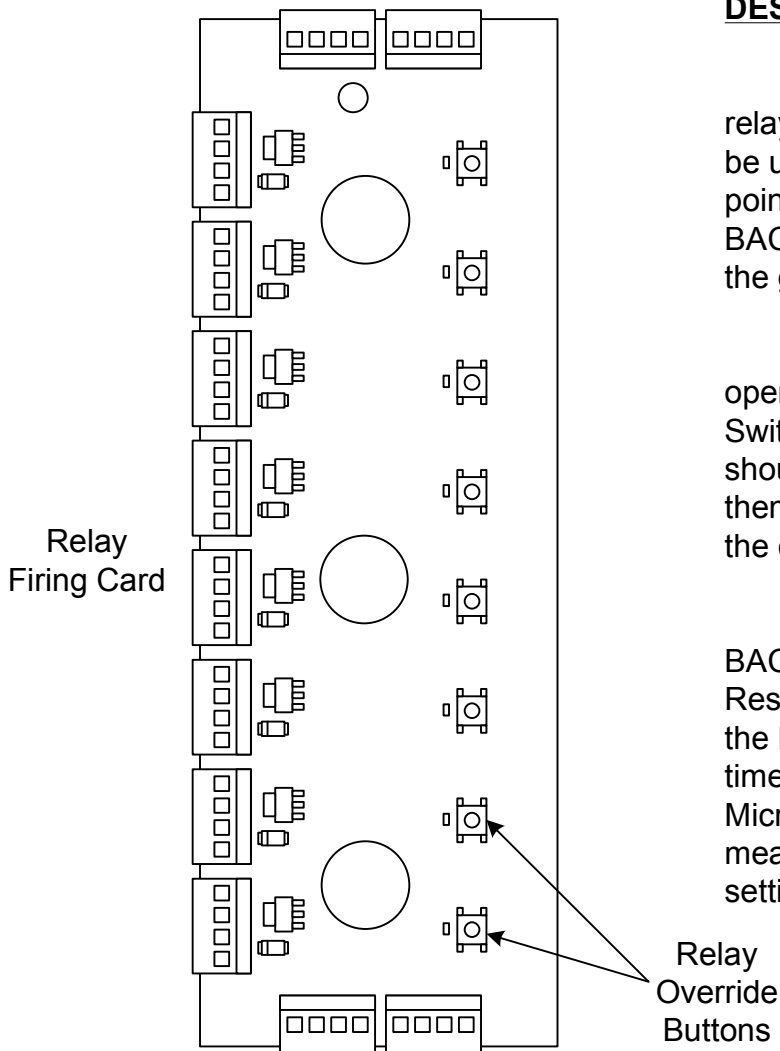
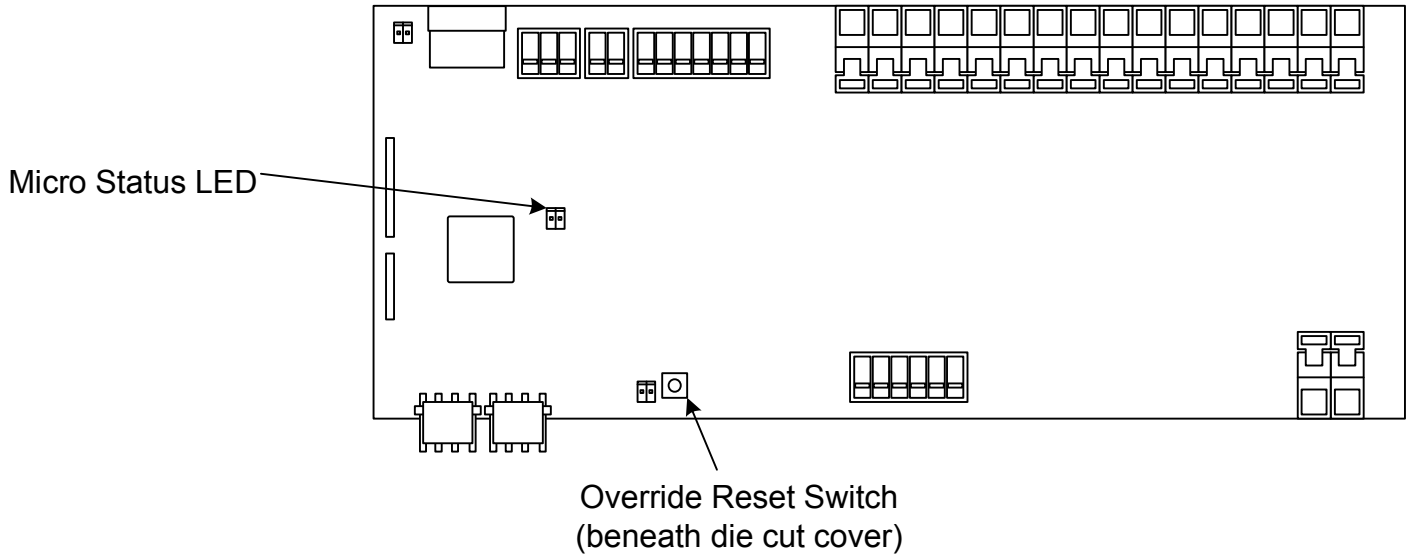

DESCRIPTION OF OPERATION

Under normal operating conditions, each relay has its own Relay Override switch that can be used to turn each relay **on** or **off** at any given point. When an override switch is pressed, the BACnet system will then ignore all commands for the given relay(s) until the override is cleared.

To clear the overrides, and restore normal operating conditions, press the Override Reset Switch for one second. The Micro Status LED should blink Red/Green once and the relays will then be switched back to the proper state under the control of the BACnet system.

To restore factory settings on the BACnet system, press and hold the Override Reset Switch for ten seconds. While doing this, the Micro Status LED will flash Red/Green ten times. When the system reset is complete, the Micro Status LED will blink Red once. This will mean the system has been restored to factory settings.

Vender Name: **Touch-Plate, Inc.**

Product Name: **CPS-XX-BAC-M Lighting Control Panel
 CPS-XX-BAC-E Lighting Control Panel**

Product Model Number: **CPS-XX-BAC-M (where XX = 8, 16, 24, 32, 40, or 48 relays)
 CPS-XX-BAC-E# (where # is the number of I/O cards)**

Applications Software Version: **1.07**

Firmware Revision: **2.47**

BACnet Protocol Revision: **4 (135-2004)**

Product Description:

This unit is a lighting control panel with 15 binary inputs and up to 48 relays represented as binary outputs. The number of relays can range from 8 to 48 in increments of 8. The panels use the Touch-Plate 4000-PL relay. This relay can switch loads rated to 20 amps at 277 VAC Tungsten or Ballast. MS/TP MAC address, baud rate, termination and biasing may be set using DIP switches. The inputs support subscribed and unsubscribed Change Of Value (COV) operation. Relays can be overridden at the panel for maintenance and service purpose.

BACnet Standardized Device Profile (Annex L):

BACnet Application Specific Controller (B-ASC)

BACnet Interoperability Building Blocks Supported (Annex K):

DS-RP-B, DS-RPM-B, DS-WP-B, DS-WPM-B, DS-COV-B, DS-COVU-B, DM-DDB-B, DM-DOB-B, DM-DCC-B

Segmentation Capability: Not supported.

Standard Object Types Supported:

<i>object</i>	<i>create</i>	<i>delete</i>	<i>optional properties</i>
Binary Input	No	No	DEVICE_TYPE, RELIABILITY, INACTIVE_TEXT, ACTIVE_TEXT
Binary Output	No	No	DEVICE_TYPE, RELIABILITY, FEEDBACK_VALUE INACTIVE_TEXT, ACTIVE_TEXT

Data Link Layer Options: MS/TP master, Baud rate(s): 9600, 19200, 38400, 76800

Device Address Binding: Is static device binding supported? No

Networking Options: No routing or BBMD functions are supported.

Character Sets Supported: ANSI X3.4

Dimension:

All dimensions are in inches (mm)

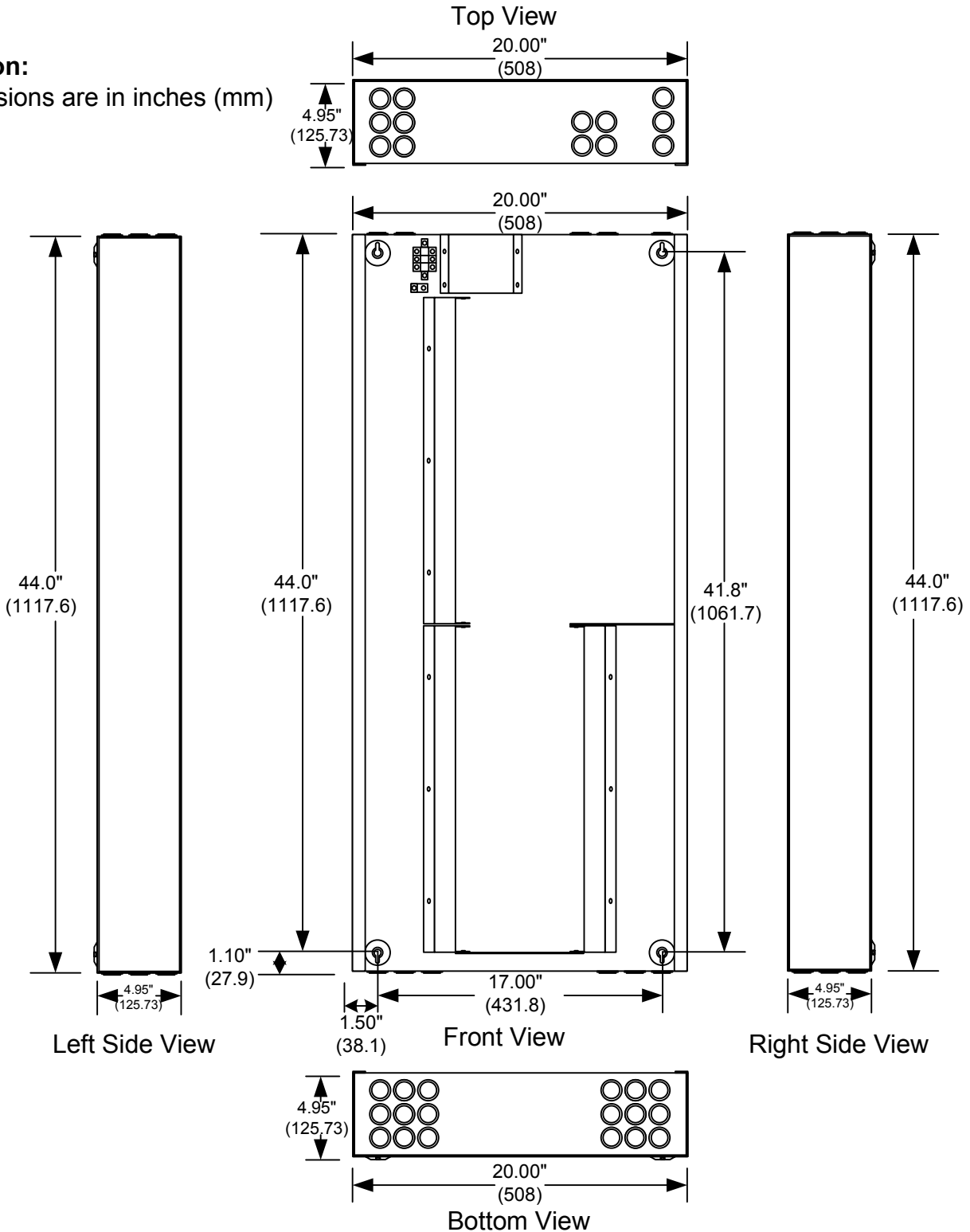

Weight:

Enclosure Only: 51.4 Lbs.

Enclosure w/ 32 Relays and Transformer: 68.2 Lbs.

Enclosure w/ 40 Relays and Transformer: 71.4 Lbs.

Enclosure w/ 48 Relays and Transformer: 74.6 Lbs.

Enclosure Type:

NEMA 1

(For Indoor Use Only)

Mounting:

- For indoor use only!
- Consult dimensions page for panel size, conduit knockouts, and mounting holes.
- Mount panel where audible noise is acceptable. (Internal relays click)
- Mount where ambient temperature is 32-104° F (0-40° C)
- Mount panel so line (mains) voltage wiring is at least 6 ft. (1.8m) from sound or electronic equipment and wiring.
- Mount within 7° of true vertical.

Surface Mounting:

- Touch-Plate recommends using 0.25 in. (6 mm) mounting bolts with 1.0 in. washers.

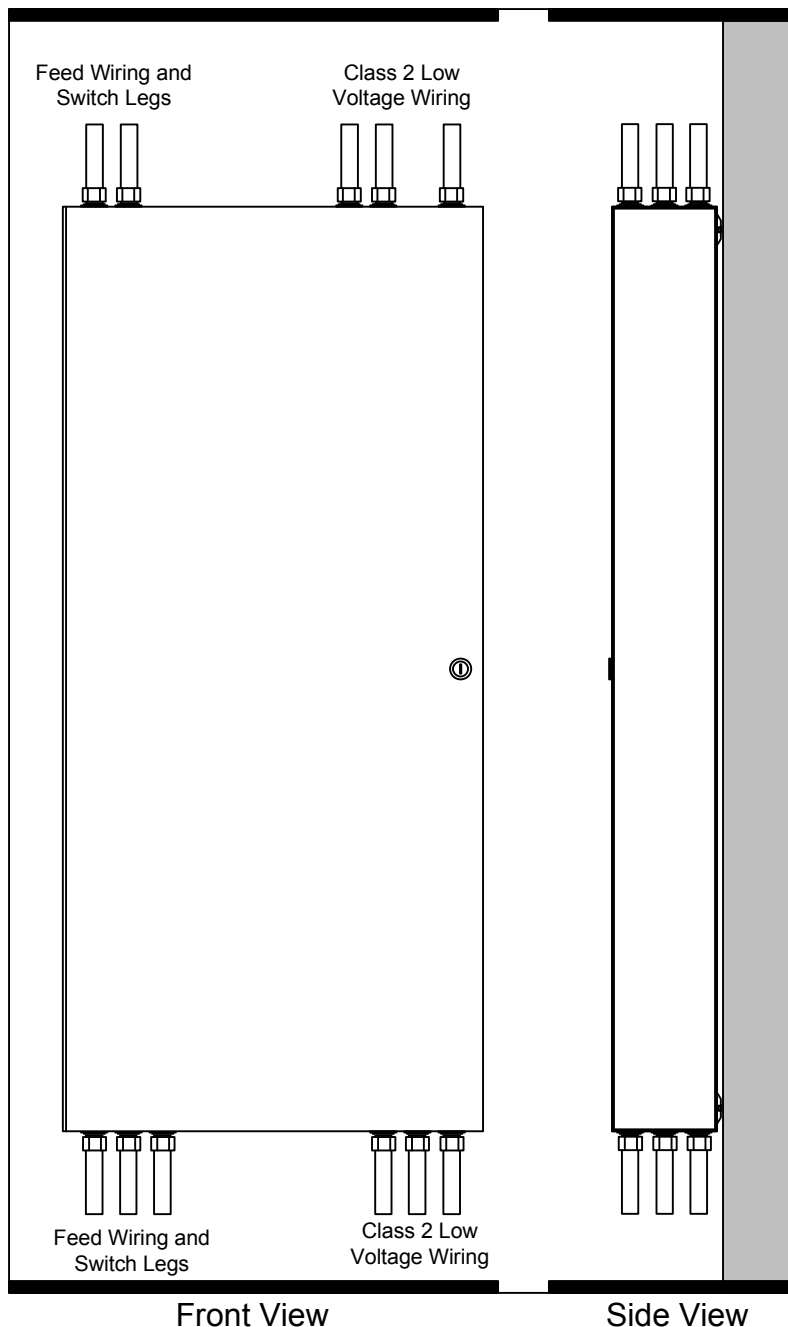

Front View

Side View